

Webster[®]

Fuel Pumps & Valves

A Division of Capital City Tool, Inc.

An ISO 9001:2008 Company

OUR PLEDGE TO YOU:

When you buy Webster products, you buy total service. Webster is the unique, single-source supplier of an extensive line of heating products. We manufacture fuel units, supply and transfer pumps, valves and oil heat accessories. And we constantly seek better solutions and set higher standards for the oil heat industry.

Webster is committed to reliable servicing of its products. As always, our field service people provide professional schooling and make training materials and demonstration units available for training.

We are ready to work with you to help solve your specific heating problems.

This Webster® Service Technician's Handbook is supplied as a service to our customers, dealers and installers. It represents our efforts to share with them our experiences of many years with our products in the field, and to also provide condensed catalog information to you on Webster products.

This booklet is not intended to be all-inclusive, or to be directly applicable to products manufactured by any other company.

It remains the complete responsibility of all parties involved in the design and installation of any system involving Webster products to insure that the design and installation of the system is correct for the individual circumstances, and that the system is installed in compliance with all applicable codes, standards, regulations or other restrictions.

Neither Webster, nor any of its authorized representatives, assume any responsibility, obligation or liability relating to the design and/or installation of any systems utilizing Webster component parts, and nothing contained in this Service Technician's Handbook should be construed as constituting any extension of its standard Warranty Policy as stated in this booklet.

Webster®

Fuel Pumps & Valves

Warranty Policy

Webster warrants that Products shall be free from defects in materials and workmanship for a period of two (2) years from the date of manufacture or one (1) year from the date of installation, whichever period expires first. Webster will rebuild or replace, at its option, all Products proven to its satisfaction to be defective within such warranty period and returned to the Webster factory transportation charges prepaid. Webster's sole obligation and buyer's exclusive remedy hereunder is limited to such rebuilding or replacement.

No products may be returned to Webster unless the prior written consent for said return shall have been obtained from the Customer Service Department in Frankfort, Kentucky. This Limited Warranty does not cover shipping costs to and from the Webster factory, any costs for labor or otherwise related to product removal or replacement, or any other costs of any nature without prior written consent by Webster.

Parts, products and accessories made by others are warranted only to the extent of the original manufacturer's warranty to Webster.

This warranty shall not apply to acts of God, war or civil insurrection, nor shall it apply to products which, in the sole judgment of Webster, have been subject to negligence, abuse, accident, misapplication, tampering, alteration; nor due to other than normal application, use or service, including but not limited to, operational failures caused by corrosion, rust or other foreign materials in the system, or operation at pressures in excess of recommended maximums.

Purchaser shall be solely responsible for determining suitability for use of Webster Products. Webster shall not in any event whatsoever, have any liability with respect to such determination.

THE FOREGOING WARRANTY IS EXCLUSIVE AND IN LIEU OF ALL OTHER WARRANTIES, EXPRESS OR IMPLIED, INCLUDING BUT NOT LIMITED TO THE IMPLIED WARRANTIES OF MERCHANTABILITY AND FITNESS FOR A PARTICULAR PURPOSE. WEBSTER SHALL NOT BE LIABLE FOR ANY CONSEQUENTIAL, INCIDENTAL OR CONTINGENT DAMAGES WHATSOEVER.

NOTE TO CONSUMERS: THIS LIMITED WARRANTY IS EXTENDED TO THE COMMERCIAL CUSTOMERS, DEALERS AND INSTALLERS OF WEBSTER ONLY. THE SUPPLIER / INSTALLER WILL EXTEND WARRANTY COVERAGE TO YOU WHICH COVERS WEBSTER'S PRODUCTS. WEBSTER'S WARRANTY TO SUCH CUSTOMERS, DEALERS AND INSTALLERS WILL BACK UP THE WARRANTY EXTENDED TO THE CONSUMER.

TABLE OF CONTENTS

FUEL UNITS	1
General Information	1
Oil Heating Terminology	1
How A Fuel Unit Works	1-2
Basic System Installations	3-4
Installation and Service Tips	5-12
Service Call Checklist	13-14
Metering Pump	14-15
M Series Fuel Units	16
Single- and Two-Stage	16
M34DK-3 Series Fuel Units	16
Single-Stage	16
Fuel Unit Specifications	17
Code Analysis	18
Selection Tables and Dimensions	19
Fuel Unit Cross Reference	19-20
Installation Data	21-25
BIO Pump	26-29
Waste Oil Pumps	30-33
R Series Service Saver Fuel Units	34
Fuel Unit Specifications	34
Selection Table—Single-Stage	35-37
Selection Table—Two-Stage	38-40
R Series Code Analysis	41
Fuel Unit Cross Reference	41-42
Installation Data	43-50
1 R00 Series Single-Stage Transfer Pumps ...	51
Fuel Unit Specifications	51
Selection Table	52
R Series Fuel Unit Code Analysis	52
Installation Data	53-54
V Series High Delivery Fuel Pumps	55
Fuel Unit Specifications	56
Selection Table	57-58
V Series Code Analysis	59
Installation Data	60-62
B Series Fuel Oil Transfer Pumps	63
Fuel Unit Specifications	63-64
Selection Table	64
Typical Performance Curves	65-66
Installation Data	67
SUPPLY PUMP UNITS	68-69
General Information	70
SPM Series Supply Units	71
Duplex Pump Units—SPM Series	72
Supply Unit Specifications	73
Selection Tables	74-75
Supply Unit Cross Reference	75
Duplex Automatic General Info.	76-80
Installation Data	81-84
SPM Line Sizing	85
Suction Line Sizing Charts	86-89
Discharge Line Sizing Charts	90-97

SPM Duplex Automatic Controls	98
Electrical Connections	99
SPMV SERIES	100-101
Fuel Unit Specifications	102
SPMV Code Analysis and Selection Tables	103
SPMV Flow Chart Dimensions	104-106
PLC BASED DUPLEX AUTOMATIC	
PUMP SETS	107-109
Discharge Manifold Description and Set-Up	110
Containment Basin	110
SPMB SERIES	111
Specifications	112
SPMB Code Analysis	113-114
SPMB Dimensions	115-116
TRANSFER PUMP/MOTOR UNITS	117
Specifications	117
35223 Series Transfer Units	118
Selection Table	118
35202 Series Transfer Units	119
Selection Table	120-121
49116 Series Transfer Units	122
Selection Table	122
FUEL UNIT ACCESSORIES	124
Mounting Accessories	124
Selection Table	124
Dimensions	125
VALVES	126
OSV[®] Oil Safety Valves	126
Operation	126
BIO-OSV Upgrade	126
Section "A"	126
Installation	127
Troubleshooting	127-128
Section "B"	128
Installation	128-129
Open Loop System	130
General Considerations	130
Porting Connections	130
Mounting	130
Filter	130
Priming	130
Check Local Codes	130
Regulating Valves for Oil Heating	131
RV Series	131
Specifications Dimensions	131-132
Selection Table	133
Installation Data	134
Relief Valve	135
Vacuum Breaker (48598)	136
Installation Data	136
TROUBLESHOOTING	
General Pump Problems	137-139
MANUFACTURER'S REPRESENTATIVES	140-141

FUEL UNITS

GENERAL INFORMATION OIL HEATING TERMINOLOGY

As with most major industries, oil heating has developed a language of its own which contains a number of terms not encountered elsewhere. The following list includes the terms which are most common to the oil heating industry.

Single-stage fuel unit: unit with one set of gears for both suction and pressure.

Two-stage fuel unit: unit with two sets of gears, one for suction and one for pressure.

One-pipe system: one line, an line, from tank to fuel unit.

Two-pipe system: two lines, one inlet and one return line, from tank to fuel unit.

Bypass plug: small hex socket head pipe plug used to close internal port and convert unit from one pipe to two pipe operation.

Bleed: to remove air from system.

Lift: oil drawn from a level below pump expressed in feet of lift or inches of mercury.

Head of oil: column of oil over fuel unit expressed in psi or feet.

Inlet port: port which receives oil from tank.

Bypass port: port which discharges surplus oil back to tank in two-pipe system.

Return line port: same as by-pass port.

Valve differential: number of pounds per square inch the pump pressure must drop from operating pressure to close nozzle valve.

Delivery: gallons per hour pumped from the nozzle outlet assembly of the fuel unit.

Gear Set Capacity: Total amount of oil being displaced by the pumps gear set(s).

HOW A FUEL UNIT WORKS

The fuel unit performs three basic functions:

1. Supply the Oil. The pumping action, of the fuel unit is accomplished by the gearset. In a single-stage fuel unit there is only one set of gears. Their function is to draw oil from the tank and deliver the oil to the nozzle under sufficient pressure to ensure the oil is properly atomized for combustion. A single-stage fuel unit is generally

used where the fuel supply tank is above the burner or where the inlet vacuum is limited to 10" Hg or less when measured at an unused inlet port.

A two-stage fuel unit has two sets of gears. The suction gearset creates a vacuum within the fuel unit which draws oil from a submerged tank or a tank located below the oil burner and discharges it into an intermediate chamber or reservoir which supplies the pressure gears. The pressure gearset delivers oil under pressure to the burner nozzle. Thus, the pressure gears do none of the lifting.

2. Clean the Oil. Clean oil is essential for the efficient operation of any oil burner. The purpose of the filter is to protect the nozzle from foreign particles or any other matter that might clog the minute nozzle opening. Webster fuel units utilize our exclusive rotary filter which reduces the need for troublesome periodic cleaning. The rotary filter's blades rotate at motor speed with constant cleaning action to minimize clogging, compared to strainer type filters. For maximum protection, an additional line filter should be used, in accordance with recommended standard practice.

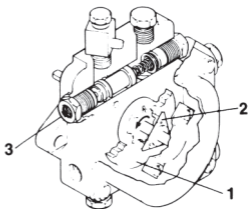

3. Build Pressure and Provide Clean Fuel Cutoff Probably the most important functions of the fuel unit are to build pressure to properly atomize the fuel oil and to provide clean cutoff of oil when the burner shuts down. These functions are primarily performed by the valve assembly consisting of a pressure regulating spring, pressure adjusting screw, valve and valve seat, working in conjunction to the gearsets.

The pressure regulating spring and the pressure adjusting screw determine the pressure at which oil is delivered to the nozzle. For example, when the spring in a valve assembly is set for 100 pounds per square inch pressure the valve will not open until the pressure gears have built up enough pressure in the valve chamber to raise the piston from its seat. This prevents oil from reaching the nozzle while under too low a pressure for correct atomization. The valve and valve seat control the flow of oil. They also are responsible for a sharp clean cutoff when the pressure within the fuel unit drops below the setting of the valve spring. Webster's M34DK-3 fuel unit has exceptionally fast fuel cutoff through the additional use of an internal flow control device.

BASIC SYSTEM INSTALLATIONS

There are two basic types of installation for fuel units: one-pipe systems or two-pipe systems.

The first of these, a one-pipe system, should not be confused with a single-stage fuel unit. A one-pipe system can be installed employing either a single-stage or a two stage fuel unit. It is used where a gravity flow of oil is available.

In a one pipe (single- or two-stage) system, the internal pumping capacity exceeds nozzle requirements. The excess flow is bypassed by the internal regulating valve and is recirculated within the pump. In the one-pipe connection, inlet line flow equals nozzle flow rate.

The second basic type is known as a two-pipe system and should always be used wherever the oil supply level is below the fuel unit, whether it be a single or two-stage fuel unit.

On a two-pipe system there is a second pipe, called a return line, between the fuel unit and the tank. The excess oil over and above that required by the nozzle is bypassed at the valve and returned to the tank.

A single-stage unit on a two-pipe system can be used on lifts up to 10" HG. On the other hand, a two-stage with a two-pipe system may be used on lifts up to 15" HG.

Existing Inside Tank Installation- One Pipe System Tank Above Burner Level

With the conventional one pipe gravity feed installation both furnace and water heater can be operated off the same suction line. Merely tee off the present line to water heater as shown in drawing below making sure oil supply is above burner level at all times.

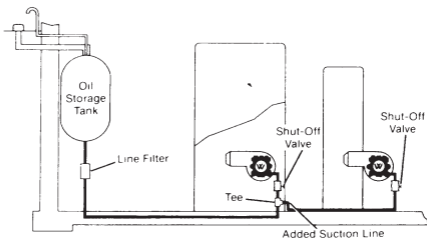

Existing Outside Tank Installation— Tank Above Burner Level

The water heater may be added to the system by connecting the suction line to the furnace suction line as

shown in drawing below. No return line is necessary from the water heater as the system is flooded due to the siphoning action when the tank is above burner level.

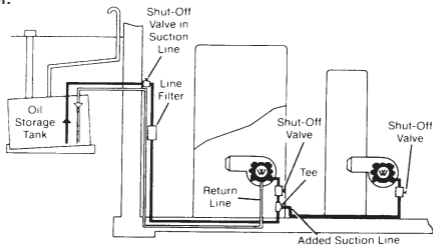

Existing Outside Tank Installation – Tank Below Burner Level

The water heater may be added to the system by installing a check valve in the suction line at both fuel units as shown in drawing below. Both units must be set for (2) two-pipe operation. This method should only be used when it's impossible to add an independent suction line to the water heater as shown in bottom drawing

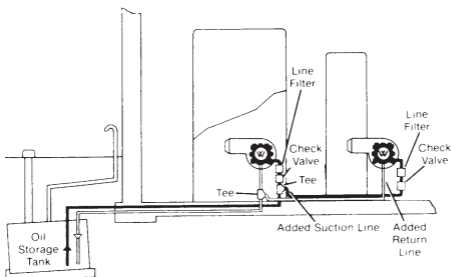

New Outside Tank Installation – Tank Below Burner Level

Individual suction lines should be used on all new installations. Return lines may be manifolded as shown in drawing below.

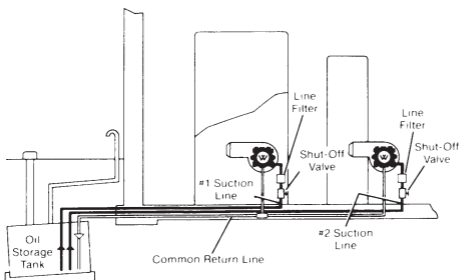

INSTALLATION AND SERVICE TIPS

When installing and servicing oil heating fuel units, several key points including service tools, use of proper tubing sizes, fuel supply cut-off, and possible causes of seal failure should be understood.

Effective Gauge Use

There are valuable tools needed in servicing any fuel unit, the two most essential are the pressure gauge and the vacuum gauge. It is factually known that if these gauges were used consistently, 75% of the fuel units sent in for repair would never need to be removed from the burners. With the correct use of these two gauges, it is possible to check vacuum, lift, air leaks, delivery, pressure and cut-off.

Vacuum Gauge

The vacuum gauge can determine the existence of air leaks in the suction line. For example, if checking a system in which the tank is buried below the burner level and the oil passes through a line filter, the vacuum gauge must show a reading. If the gauge does not show a reading, an air leak is present.

NOTE: When installing fuel units, to assure compliance with National Fire Protection Association's bulletin 31, "Installation of Oil Burning Equipment", fuel unit inlet pressures should not exceed 3 psig.

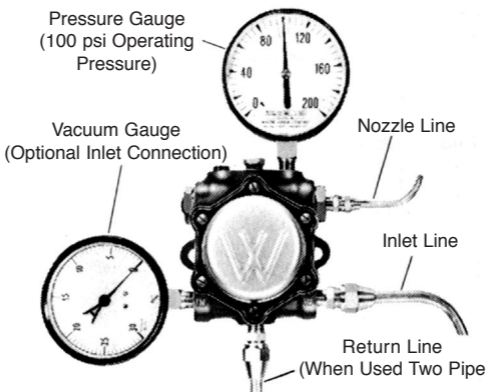

Vacuum Data

Before removing a fuel unit from an oil burner, a check should be made with vacuum and pressure gauges if you suspect fuel unit trouble.

The vacuum gauge should be applied to the inlet port ("IN") opposite the inlet port being used, or inserted in the inlet line with a "TEE".

On installations where the oil tank is below the fuel unit, the gauge reading should show the amount of vacuum (*approximately 1" vacuum per 16" of vertical lift, plus the tube loss of total run*).

NOTE:

1. The viscosity chosen for the above figures is 50 SSU. The above losses will be reduced at lower viscosities.
2. The gravity chosen is 40° API (60°F) at 68°F, which gives a specific gravity of 0.822. Gravity of No. 2 oils varies from 30° to 45° API.
3. Even though a fuel unit is capable of a very high vacuum, this has very little to do with the maximum advisable lift because of the volatility of the oil under vacuum, which varies with different oils. Under certain conditions, installations as high as 28 feet have operated satisfactorily with a two-stage unit, but generally high lifts should be avoided on any liquid having volatile fractions. When the combined vertical lift and the equivalent losses through the tubing add up to 10" vacuum or more for single-stage pumps, 15" vacuum or more for two-stage pumps, use of a Webster supply pump unit is advisable.

If the vacuum gauge reads higher than the calculated vacuum, look for restriction in the suction line ... a closed tank valve, kinked copper tubing, plugged filter, sticking foot or check valve, frozen oil line, undersized oil line, or excessive oil lift. On the other hand, if the gauge reading is below the calculated vacuum, look for air leaks in the lines, valve, fittings, or fuel unit.

On gravity fed jobs where the oil tank is above the fuel unit, vacuum should read zero except when restrictions are apparent such as closed shut-off valve, clogged filter, kinked line, etc. Any of these restrictions should be eliminated.

Relation between vacuum and vertical lift
40° API all at 68° F

Ins. of Vacuum	Lift	Ins. of Vacuum	Lift	Ins. of Vacuum	Lift
1	1'4"	8	11'0"	15	20'7"
2	2'9"	9	12'4"	16	22'0"
3	4'1"	10	13'9"	17	23'4"
4	5'6"	11	15'1"	18	24'9"
5	6'10"	12	16'6"	19	26'1"
6	8'3"	13	17'10"	20	27'6"
7	9'7"	14	19'3"		

Pressure Gauge

The pressure gauge, on the other hand, shows whether the gears are pumping and building up a steady even pressure to deliver oil to the nozzle. It also shows whether the shut-off valve in the nozzle line is giving a positive cut-off of the oil flow.

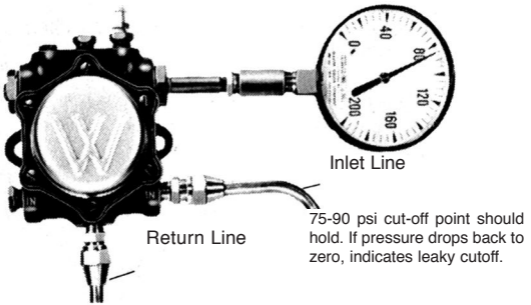

Pressure Data

A pressure gauge applied to the pressure gauge port reveals the pressure to which the fuel unit has been regulated. An adjustment can be made to suit the firing conditions (usually 100 psi). Also the pressure gauge, when applied to the pressure gauge port, can be used to check fuel unit efficiency. A unit in satisfactory operating condition should be able to support a nozzle at full spray, up to several psi above the rated burner pressure. Fuel unit manufacturers typically rate domestic units for maximum burning rate at a nominal 100 psi. Collapse of nozzle spray below specified limits indicates either excess bypass, missing or damaged valve gasket, worn valve piston or sleeve, worn gear set, or pump RFS less than nozzle rating. Pumping capacity also decreases under correspondingly higher lift (or vacuum).

A pressure gauge applied directly to nozzle outlet port for cut-off check should hold differential pressure on shutdown. For example, with operating pressure of 100 psi, the cut-off should be approximately 80 psi. If the pressure gauge drops below the cut-off point, this would indicate a leak at cut-off, therefore the valve assembly should be disassembled, cleaned or replaced if necessary. Cut-off pressure must never be more than 20% below set operating pressure.

To determine what pressures should be provided by each pump, refer to the selection charts in the desired model sections.

Correct System Tubing Sizing

Many people both in engineering and in service make the mistake of laying out and installing jobs with tubing which is too small in diameter and too long in length. If

a fuel unit with a pumping capacity of not more than 30 gallons per hour is used, tubing of 1/2" OD can be used with safety.

The tubing size can vary widely depending upon flow rate. See the pipe sizing charts for help in determining which tubing size is best suited for each application.

To Determine Suction Line Size in Installations Using Webster Fuel Units on Two-Pipe Systems

1. Check suction gear capacity (see table of pumps).
2. Measure total tube length (horizontal and vertical).
3. Refer to "Friction Tube Loss Chart" for desired tubing size. Read up from line "total feet of copper tube" to "suction capacity" in gph.
4. Read left to column "inches of vacuum at fuel unit". (This is vacuum required to draw oil through tube listed of given length.)
5. If installation has lift add .75" of vacuum for every foot of lift.

Rule of Thumb:

A quick rule to check an installation is to figure 1" of vacuum for every foot of vertical lift, and 1" of vacuum for every 10' of horizontal run. Refer to Frictional Tube Loss charts for actual installation data.

6. Total inches of vacuum (frictional tube loss plus lift if any).
7. If total is over 10" when single stage is employed on two-pipe system, check on next larger tube size chart for proper tube size.
8. If total is over 15" when two-stage unit is employed on a two-pipe system, check on next larger tube size chart.
9. The above does not allow for any added restrictions such as line filter, elbows, sharp bends, check valves, etc.

On high lifts and long runs, too small tubing will cause the oil to separate and have a milky appearance. This is not air, it is actually light, volatile portion of the oil separating from the heavy portion. This is likely to occur any time the vacuum gauge shows a reading of 15" or more, and may occur at a lower vacuum with some oils. When vacuums of 20" to 22" are reached, the pressure gauge will start to bounce and delivery at the nozzle will begin to fall off. To correct these conditions, check the tubing. If the tubing size is correct and there are no kinks or other restrictions, a supply or booster pump may be

required to assure the fuel unit of a solid column of oil. This is especially desirable where a series of suspended furnaces are included in the system with high lifts and long horizontal runs.

**FRICTION TUBE LOSS CHARTS —
#2 FUEL OIL**

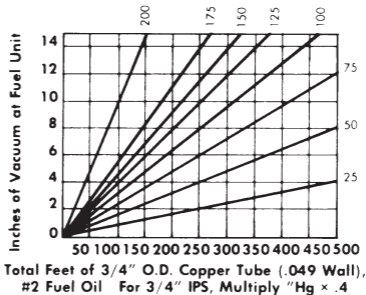
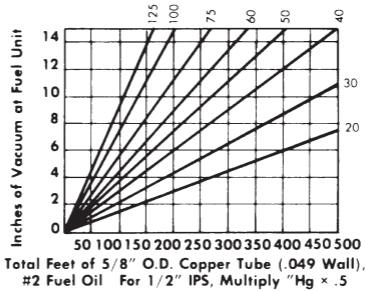
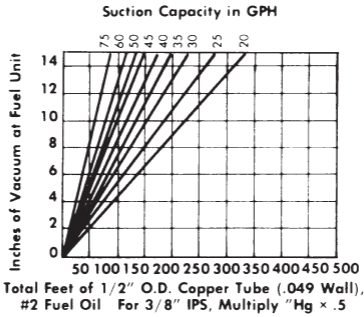
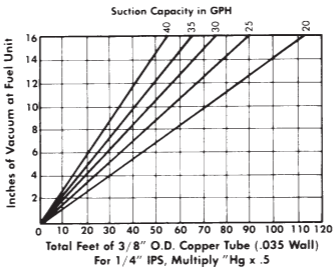

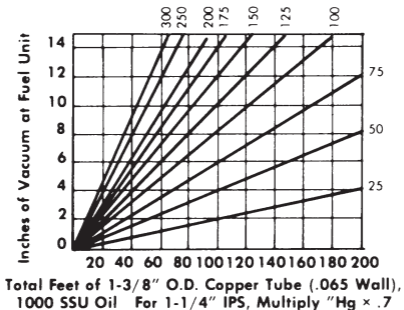
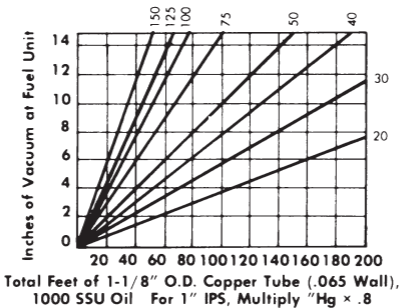
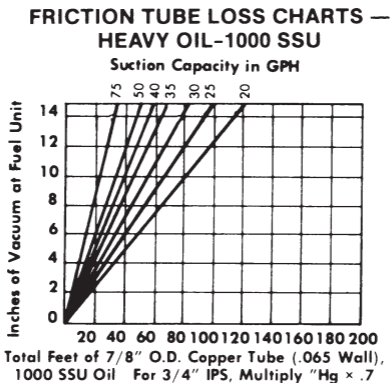
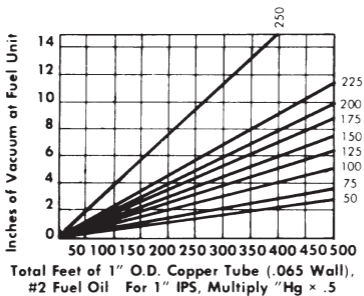

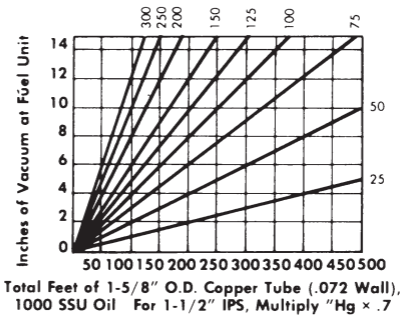

Checking Fuel Cut-Off

Another error made by some is to say the valve is faulty or the unit has a poor shut-off when the real trouble is air trapped in the nozzle line between the fuel unit valve and the nozzle itself.

This condition is generally found when a new installation is made or when air enters the suction line due to poor joints. This is particularly true on high vacuum installations. When air is mixed with oil and pumped through the fuel unit into the combustion chamber, a good fire can result while the burner is in operation. However, on shut-down the valve closes and the air becomes trapped between the valve and the nozzle itself. This air is no longer under pressure and the bubble expands forcing the oil through the nozzle orifice into the combustion chamber. This is not poor cut-off but trapped air causing the oil to squirt. It is necessary to have a tight installation and to purge all air in order to have clean sharp cut-off.

REMEMBER: A squirt out of the nozzle after the burner stops means that air is trapped. Get rid of the air and the problem will be gone.

This condition is found less often in a two-pipe system because air is picked up in the suction line, is discharged into the by-pass chamber of the fuel unit and returned to the tank if the leak is not too large. However, air can be trapped in the nozzle line of the two-pipe system. Several hours of burner running may be necessary before the air is absorbed by the oil and passed through the nozzle.

Fast Cut-Off Required

Unlike heating equipment of the past, compact boilers, furnaces, domestic water heaters, and burners made today require substantially faster shut-off to eliminate pulsation on starts and stops. The valve must open and close while the fan speed is high to provide enough oxygen for complete combustion. This may be accom-

plished by using a solenoid valve which cuts off the flow of oil instantly on shut-down.

Since the use of a solenoid is often costly for some installations, Webster offers the M34DK-3 as a fast shut-off alternative. In this unit the valve opens and closes at approximately 2,400 rpm fan speed. At this speed the air pattern is well established, both in the tube and in the chamber, and the burner operates without a smoke plume, eliminating pulsation on starts and stops. The volume of air delivered by the fan at such a speed provides the oxygen necessary for complete combustion insuring clean, quiet operation when the burner is set at maximum efficiency.

Checking Seal Leaks

Seal leaks generally do not occur; they are caused. It must be remembered that a seal can be operated under conditions ranging from high vacuum to pressure (psi). Where there is a head of oil over the fuel unit, a pressure gauge can be installed in the suction port of the unit to check head pressure. If the head pressure is over 3 psi an oil safety valve (OSV) should be installed in the suction line between the oil tank and the unit.

This also holds true where there are pressurized lines leading to the fuel unit, such as a series of suspended furnaces being served by a supply pump.

REMEMBER: To comply with NFPA standards, fuel unit inlet pressures must be limited to 3 psi.

If Pump Doesn't Work, Check for Air Leaks

90% of start-up problems are due to air leaks in the suction line. Be sure to double check for air leaks if there are problems with poor cutoff, noisy operation, or erratic fire.

To inspect for air leaks, check to be sure return line is submerged. Also, check all fittings, all joints, and the optional inlet plugs for tightness.

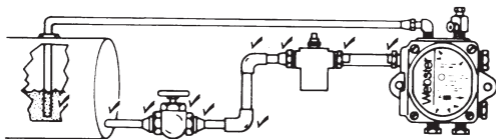

Check for air leaks:

- Return line must be submerged
- Check all fittings
- Check all joints
- Check optional inlet plugs
- DO NOT use compression fittings

90% of start-up problems are due to air leaks in the suction line . . . So check and double check for air leaks.

Filter Use

Both the Webster M and R Series contain an internal rotary filter. In addition to this filter, it is recommended that an external filter be used. The self cleaning rotary filter is designed to prolong fuel unit life and reduce fuel unit maintenance. It is not intended to be a replacement for the external filter.

IMPORTANT: Use of non-hardening oil pipe dope is recommended on threads of all fittings. Do not loosen or try to tighten any pump plugs not to be used in the installation. Do not use Teflon Tape. Evidence of teflon tape use will be cause to void all warranties.

SERVICE CALL CHECKLIST

The following procedure has been established to help save on service time and needless work when checking a "no heat" service call. This procedure is intended to be used by qualified heating service technicians only.

1. Check the thermostat to make sure that corrosion, dust or other foreign matter are not causing faulty contact and switches are properly set.
2. Check both the main fuses and the oil burner circuit fuses. Replace if required.
3. Check the oil supply and the shut-off valve in the oil line. Adequate oil and open valve are required.
4. Open the door of the heating plant and see if there is raw oil on the walls of the combustion chamber
5. Leave the inspection door open and press the burner oil reset button.
6. Check the oil burner controls in accordance with the oil burner manufacturer's instructions.
7. If at any point on the foregoing checks the burner operates, observe it for two or three complete cycles to determine whether the stoppage may occur.
8. If the burner does not operate, check to see if motor, fan and pump shaft are all rotating.
9. If there is oil spray but no ignition, check all electrical connections and the transformer.
10. If the electrical connections and transformer are operating properly, remove the firing assembly and check the electrodes for coking, spading, and cracked porcelains.
11. While the firing assembly is out of the heating plant, clean or replace nozzle.
12. If no oil spray appears, check the line filter and the fuel unit, using vacuum and pressure gauges.

Vacuum gauge check usually covers the suction side of the system.

Pressure gauge determines efficiency of pumping gears and valve. The valve can be serviced in the field. Worn pumping elements require the removal of the fuel unit.

Though these instructions may seem obvious, strict adherence to the sequence given can save valuable service time when time is of importance.

METERING PUMP



MODEL # M17DN-M

Metering Pump for the air atomized waste oil burner market. Variable flow rates vs. RPM. Clockwise rotation looking at shaft Viton seal. This unit is comparable to the Suntec A2RA-7710 Pump.

Dimensions

Dimensions in inches, () = cm

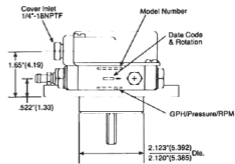
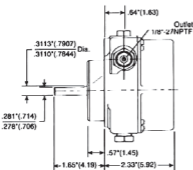
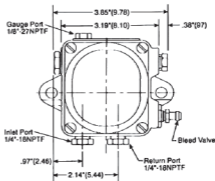
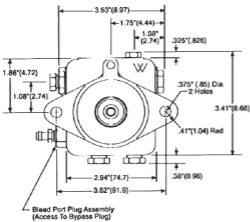

Inlet Requirements:

10" Hg maximum vacuum (approx. 10' vertical lift - exact distance will vary with tubing diameter and length). 3 psig maximum inlet pressure.

Speed:

Variable - 0 psi @ 150 rpm = 1.8 gph

Rotation: (As viewed from shaft end): Clockwise (D Style).

Porting:

- 1/8" NPTF, side located nozzle port.
- 1/8" NPTF, top located gauge port.
- 1/4" NPTF, bottom and cover located inlet ports and bottom located return port.
- Bypass plug accessible through the side located bleed port plug assembly.
- 3/8" flow through bleed valve.

Nozzle Location:

(As viewed from shaft end):
Clockwise (D Style) - Right side.

Shaft:

5/16" dia., 1.65" extension from mounting face, with keyless "D" drive.

Separate Relief or Regulator Required

Elastomers:

VITON shaft seal.
All other seals are VITON.

Mounting:

2 bolt flange - see interface dimensions.

Weight:

4 lbs., 2 oz., shipped oil-filled.

NOTE: *To assure compliance with National Fire Protection Association Bulletin 31, "Installation of Oil Burning Equipment", fuel unit inlet pressure should not exceed 3 psig.*

Available Models:

M17DN-M (1725 rpm) and M34DN-M (3450 rpm)
0-500 PSI No Internal regulator

M SERIES FUEL UNITS

SINGLE- AND TWO-STAGE

Light and extremely compact, the Webster M Series fuel units have earned a reputation for reliability and efficiency. All units include the Webster internal rotary filter. The rotary filter reduces the need for troublesome periodic cleaning. Because the filter blades rotate at motor speed with constant cleaning action, clogging is minimal compared to units that use internal filter screen. For maximum protection, an additional line filter is recommended in accordance with standard practice. Another popular feature is the easy-to-bleed valve assembly located on the side. A "D" drive reduces the harmful effects low-lubricity fuels had on previous key-drive designs. Simple flange mounting and side-located nozzle ports make the M Series ideal for fuel unit servicing. M Series fuel units are available in single- or two-stage, 1725 and 3450 rpm models with capacities to 15 gph.

M34DK-3 SERIES FUEL UNITS

SINGLE STAGE UNITS

To meet the needs of today's fuel-efficient, downsized and space efficient burners, Webster's popular M34DK-3 incorporates improved access to both the bleed valve and bypass plug. Locating the bleed port plug assembly on the side of the fuel unit provides the service technician with one visible and accessible location to either bleed the fuel unit or change the bypass plug without removing the burner. The M34DK-3 retains all of the industry accepted, state-of-the-art features of the M34DJ-3 fuel unit. These include faster fuel cut-off, improved priming on one-pipe installations, and reduced inlet line flow on two-pipe systems which results in reduced line noise.

Webster's M34DK-3 fuel unit is available in a single stage, 3450 RPM model rated at 3 GPH. Operating pressure is factory set at 100 psi and is adjustable to 150 psi. The M34DK-3 is capable of maintaining its 3 gallon per hour fire size at up to 150 psi throughout its service life.

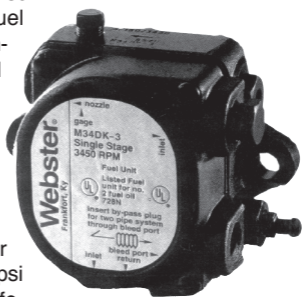

**TO BLEED
THE PUMP**



TURN THE 3/8" BLEED VALVE ONE QUARTER OF A TURN AND LET FUEL OIL FLOW UNTIL CLEAR OF AIR. RETORQUE THE BLEED VALVE. DO NOT OVERTORQUE.

**TO INSTALL
OR REMOVE
THE BYPASS
PLUG**



REMOVE THE BLEED PLUG ASSEMBLY WITH A 11/16" SOCKET TO ACCESS THE BYPASS PLUG LOCATION. INSERT OR REMOVE THE BYPASS PLUG TO CHANGE FROM SINGLE OR TWO PIPE SET-UP. RETORQUE THE BLEED PLUG ASSEMBLY.

FUEL UNIT SPECIFICATIONS

M Series

Single- and Two-Stage Units

M34DK-3 Fuel Units

Single-Stage Unit

Capacities:

M Series rated 3 gph @ 100 psi with #1, #2 fuel oil or kerosene.

M34DK-3 unit rated 3 gph fire size for pressure from 100 to 150 psi with #1, #2 fuel oil or kerosene.

Pressure:

Built in pressure regulator.

M Series factory set at 100 psi

M34DK-3 unit factory set at 100 psi, adjustable to 150 psi.

Speeds:

M Series—1725 and 3450 rpm

M34DK-3—3450 rpm.

Rotation:

Clockwise (D Style) or counterclockwise (C Style) when viewed from shaft end.

Porting:

1/8" NPTF: side location nozzle port, top located gauge port

1/4" NPTF: 2 inlets, and bottom return.

Shaft:

5/16" dia. x 1.65" extension from mounting face with keyless "D" drive.

Seal:

Double lip type Buna N.

Mounting:

Two bolt flange.

Filter:

Self cleaning rotary type internal

NOTE: External filter recommended with each installation

Weight: (shipped oil filled)

M17 models—4 lbs, 4 oz

M34 models—4 lbs, 2 oz

2M17 models—4 lbs, 12 oz

2M34 models—4 lbs, 9 oz

Maximum Inlet Vacuum:

M models—10" Hg

2M models—15" Hg

Refer to Table "Total Allowable Feet of Line" in this section.

U.L. Listed.

To assure compliance with National Fire Protection Association's Bulletin 31," Installation of Oil Burning Equipment," fuel unit inlet pressure should not exceed 3 psig. Refer to the section on Oil Safety Valves (page 119) for additional information.

M-SERIES FUEL UNIT-CODE ANALYSIS

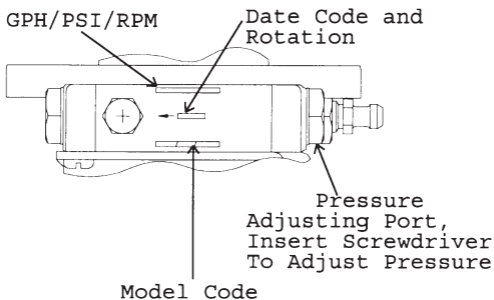

2M 17 D L - 6 *
 | | | | | |
 A B C D E F

A— M = Single Stage
 2M= Two Stage

B— 17 = 1725 RPM
 34 = 3450 RPM

C— C = CCW rotation, outlet left
 D = CW rotation, outlet right
 (as viewed from shaft end)

D— A = Key drive, face seal, old style porting
 B = Std., face seal, old style porting
 C = Special, face seal, old style porting
 D = Std. lip seal, old style porting
 E = Special, lip seal, old style porting
 F = Same as D except revised porting
 G = Same as E except revised porting
 H = Same as F except o-ring on pressure
 adjusting screw
 J = Same as H except revised internal porting
 K = Same as J except revised porting and bleed
 valve location
 L = Same as K except revised porting and
 bleed valve location

M = BIO Pump
 N = Waste Oil Pump

E— 3 = 3gph max. recommended fire size
 6 = 6gph max. recommended fire size
 15 = 15gph max. recommended fire size
 M = Metering Pump

F— No *=unit set 1 pipe
 (bypass plug not installed)
 *=Unit set 2 pipe
 (bypass plug installed)

SELECTION TABLES & DIMENSIONS

M Model Unit—Single-Stage

Models	Speed rpm	Rotation*	Style	Max. Nozzle Fire		Suction
				Location*	Size gph at 100 psi	Gear Cap.**
M17CL-6	1725	CCW	C	Left	6	32
M17DL-6	1725	CW	D	Right	6	32
M34CL-3	3450	CCW	C	Left	3	29
M34DK-3	3450	CW	D	Right	3	17
M34CL-6	3450	CCW	C	Left	6	29
M34DL-6	3450	CW	D	Right	6	29

*As viewed from shaft end

** Based on two-pipe installation

2M Model Unit—Two-Stage

Models	Speed rpm	Rotation*	Style	Max. Nozzle Fire		Suction
				Location*	Size gph at 100 psi	Gear Cap.**
2M17CL-6	1725	CCW	C	Left	6	35
2M17DL-6	1725	CW	D	Right	6	35
2M34CL-3	3450	CCW	C	Left	3	35
2M34DL-3	3450	CW	D	Right	3	35
2M34CL-6	3450	CCW	C	Left	6	35
2M34DL-6	3450	CW	D	Right	6	35

*As viewed from shaft end

** Based on two-pipe installation

FUEL UNITS (CROSS REFERENCE)

Webster Model No.	Suntec Model No.
M17DL-6	A1VA-7112
M17DL-6	A1VB-7113
M17CL-6	A1VC-7114
M34DK-3	A2VA-7116
M34DK-3	A2VB-7117
M34DK-3	A2VA-7142
M17CL-6	A1VD-7741
M17DL-6	A1YA-7912
M17CL-6	A1YD-7915
M34DL-6	A2YA-7916
2M17DL-6	B1VA-8212
2M34DL-3	B2VA-8216
2M34DL-6	B2YA-8916

Dimensions

The dimensions indicated apply to both M Model, single-stage units, and 2M Model, two-stage units. Refer to table for variable dimension X.

Dimension drawing shows nozzle, inlet and gage port locations for D Style units. C Style units are the opposite of that pictured.

The model number and rating information (gph/psi/rpm) are stamped into the machined surface on top of the pump body. Check to confirm pump is correct for the application.

Dimensions () = centimeters

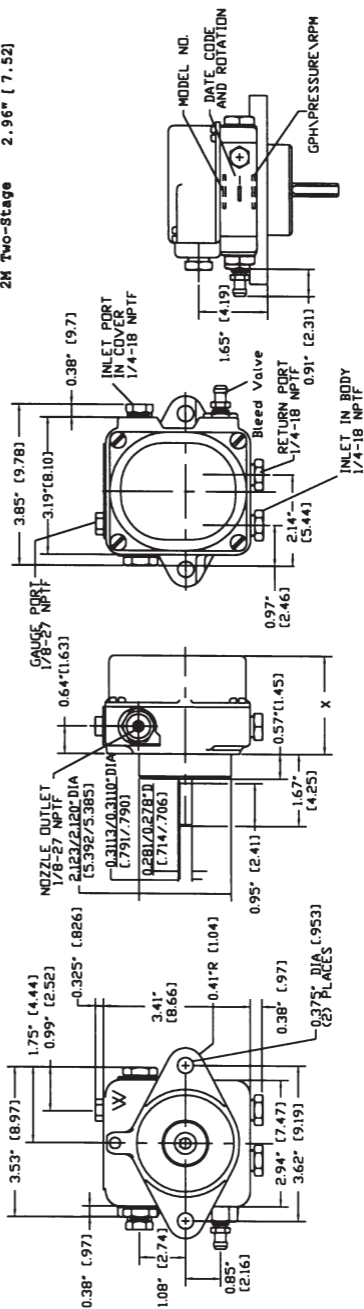

INSTALLATION DATA

M Series units may be used in one-or two-pipe installations. They have vacuum capability up to 10" Hg on single-stage units, 15" Hg on two-stage units including piping and lift losses. They are rated for use with #1 and #2 fuel oil or kerosene.

IMPORTANT: Do not loosen or try to tighten any pump plugs not to be used in the installation. **NON HARDENING OIL PIPE DOPE IS RECOMMENDED** for use on the threads of all fittings. Teflon tapes or paste must be used with care to prevent depositing tape pieces or fibers into critical internal areas of the pump. Reduced torque must be used with teflon materials to avoid thread or casting damage. **EVIDENCE OF TEFLON MATERIAL IN INTERNAL AREAS OF THE FUEL UNIT WILL BE CAUSE TO VOID WARRANTY.**

Installation Notes:

Nozzle port pressure at cutoff is not less than 80% of set pressure on all except -15 models. -15 models do not have internal cutoff.

'Fuel unit inlet pressure should not exceed 3 psig in order to comply with National Fire Protection Association's Bulletin 31.'

M Series fuel units are available in standard C Style (counterclockwise rotation, nozzle port on left, as viewed from shaft end) or D Style models (clockwise rotation, nozzle port on right, as viewed from shaft end).

Important Rating Information

Recommended fire size (RFS) of pump decreases as pump operating pressure is increased above 100 psi nominal rated pressure, except M34DK-3, which is rated to 150 psi. For adequate service life, nozzle flow at set pressure must not exceed RFS figures in table below.

Max. UL listed operating press. = 135 psi ("K"-150 psi)

Pump Model	RFS at 100 psi	RFS at 135psi	RFS at 150 psi
M34-3, 2M34-3	3 gph	1 gph	—
M34-6, 2M34-6	6 gph	3 gph	—
M34-15, 2M34-15	15 gph	13 gph	—
M17-6, 2M17-6	6 gph	3 gph	—
M17-15	15 gph	13 gph	—
M34DK-3	3 gph	3 gph	3 gph

Body Style C

Counterclockwise Rotation (CCW)

To adjust pressure:
Insert standard screw driver. Turn counterclockwise to set below desired pressure. Then turn clockwise to set desired pressure.

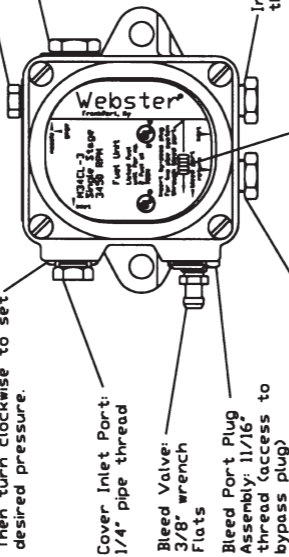

Bypass Plug: 1/16" pipe thread, 5/32" Allen P/N 29533-21

Return Port: 1/4" pipe thread

Inlet Port: 1/4" pipe thread

Bypass Plug: 1/16" pipe thread, 5/32" Allen

Color Of Printed Label Denotes Operating Speed:
Blue Background - 1725 rpm
Silver Background - 3450 rpm

Body Style D

Clockwise Rotation (CW)

To adjust pressure:
Insert standard screw driver. Turn counterclockwise to set below desired pressure. Then turn clockwise to set desired pressure.

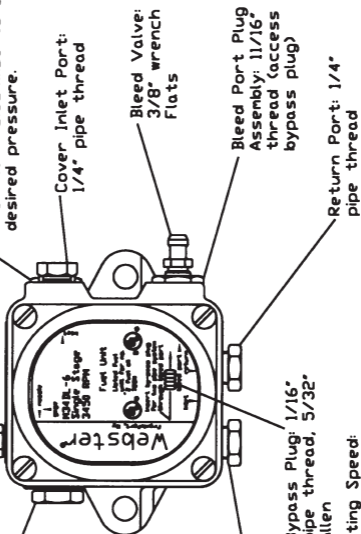

Bypass Plug: 1/16" pipe thread, 5/32" Allen

Return Port: 1/4" pipe thread

Inlet Port: 1/4" pipe thread

Bypass Plug: 1/16" pipe thread, 5/32" Allen

Total Allowable Feet of Tubing

Figures in body of table are total allowable feet of line length (vertical + horizontal) given feet of vertical lift for M pumps set 2 pipe.

Feet Vertical Lift	1-Stage All Models Except "K"		1-Stage "K" Only	
	3/8" OD Tubing	1/2"OD Tubing	3/8" OD Tubing	1/2" OD Tubing
	0	50	100	100
1	46	100	93	100
2	42	100	85	100
3	39	100	78	100
4	35	100	70	100
5	31	95	63	100
6	27	83	55	100
7	24	72	48	100
8	20	60	40	100
9	16	49	33	99
10	12	38	25	76
11		27	18	53
12		15		31
13				
14				
15				
16				
17				
18				

Feet Vertical Lift	2-Stage All Models Except - 15		2M34-15 Only	
	3/8" OD Tubing	1/2"OD Tubing	3/8" OD Tubing	1/2" OD Tubing
	0	75	100	56
1	71	100	53	100
2	68	100	51	100
3	64	100	48	100
4	60	100	45	100
5	56	100	42	100
6	53	100	39	100
7	49	100	37	100
8	45	100	34	100
9	41	100	31	94
10	38	100	28	85
11	34	100	25	77
12	30	91	22	68
13	26	80	19	60
14	23	68	17	51
15	19	57		43
16		46		34
17		34		26
18		23		

One-Pipe Installation

Normally recommended for gravity feed only. Lift up to 8 feet max. is allowable if system is absolutely airtight. Even slight air leak can cause loss of prime with 1 pipe lift.

1. Remove BYPASS PLUG (if installed) through side INLET PORT in pump body.
2. Connect inlet line to preferred INLET PORT.
3. Connect nozzle outlet to nozzle line.
4. Plug all unused ports securely.
5. Start burner and bleed all air from the system by opening VENT PLUG. Close VENT securely when oil flow in tube is clear.

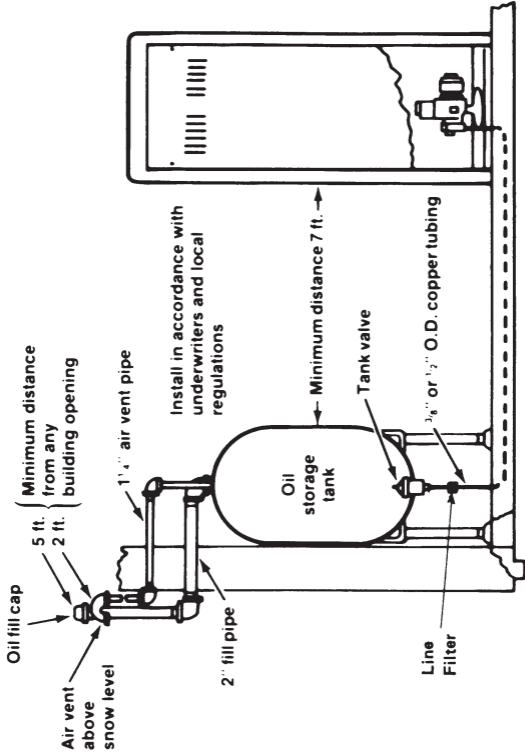

Two-Pipe Installation

Normally required when lifting oil from below pump. 2 pipe systems are self-venting. See table below for permissible line lengths.

Maximum Inlet Vacuum:

Single-stage M units — 10" Hg

Two-stage 2M units — 15" Hg

1. Insert BYPASS PLUG, if not installed, through side INLET PORT in pump body.
2. Connect supply line to preferred INLET PORT.
3. Connect return line to preferred RETURN PORT.
4. Connect nozzle outlet to nozzle line.
5. Plug all unused ports securely
6. Start burner. Unit will self vent.

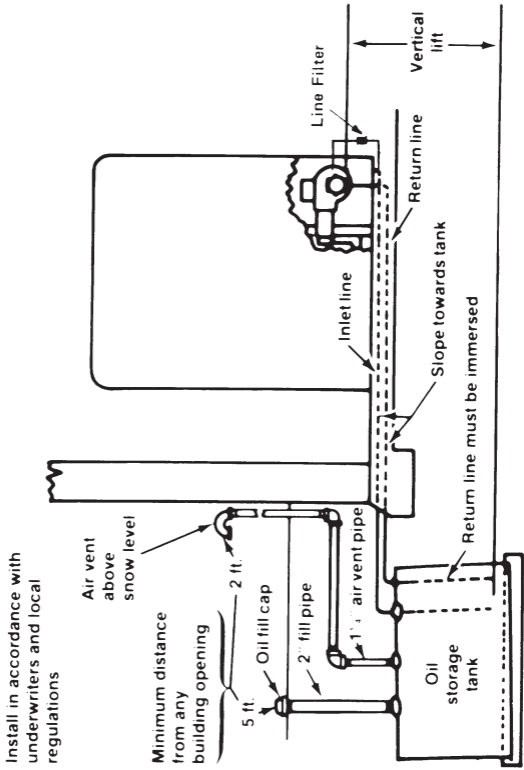

M34DM-3 Bio Pump

Features

To meet the needs of today's fuel-efficient, downsized and space efficient burners, Webster's M34DM-3 incorporates improved access to both the bleed valve and bypass plug. Locating the bleed port plug assembly on the side of the fuel unit provides the service technician with one visible and accessible location to either bleed the fuel unit or change the bypass plug without removing the burner.



In addition to improved access the M34DM-3 cleaner blade has been thickened to provide a more robust cleaning action. For maximum protection, an additional line filter should be used in accordance with recommended standard practice All of the BUNA-N elastomers have been replaced with VITON to provide extended life at critical locations within the fuel unit.

The M34DM-3 retains all the industry accepted, state-of-the-art features of the M34DK-3 fuel unit. These include faster fuel cut-off, improved priming on single pipe installations. This unit can easily replace your standard M34D or A2VA residential pump.

The M34DM-3 is capable of maintaining a three gallon per hour fire size at up to 150 PSI throughout its design life. The M34DM-3 is factory preset to 100 PSI and is adjustable to 150 PSI.

General Operation and Fuel Unit Oil Flow

The compact M34DM-3 Fuel Unit is engineered for efficient pumping of Bio fuel. The cut-away view illustrates the oil flow through an M34DM-3 operating in a one pipe system, with a suction line and no return to the storage tank.

A one pipe system is frequently used when the storage tank is located above the fuel unit, or when automatic venting is not necessary. Vacuum at the pump inlet should not exceed 10" Hg. For this type of installation to be reliable, the total system must be completely airtight. During installation or servicing of the fuel unit, air may be manually bled from the system through the side-located bleed valve.

The M34DM-3 will provide up to 10" Hg of inlet vacuum. The two pipe system (shown below), with both a suction and return line is self-venting. This allows any air in the system to escape and be returned to the storage tank through the return line.

One Pipe System

Fuel enters the fuel unit through the inlet port and is drawn into the front cover chamber. A vacuum, created by an inner and outer rotating gear set, pulls oil through the rotary filter and into the gears. As oil moves around the gears, it is compressed, creating a higher pressure. Oil leaving the gear set branches into two paths. One path leads to the pressure regulating chamber. A second path directs oil to the bleed valve. Oil flowing into the pressure regulating chamber branches into two paths. Up to three gallons per hour can flow out the nozzle port, and the remaining oil bypasses the pressure regulator, returning to the front cover chamber.

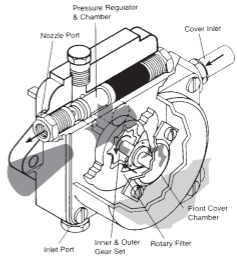

Two Pipe System

The by-pass plug, inserted through the bleed valve port, blocks the surplus oil return to the front chamber. This oil is directed to the return port and back to the storage tank.

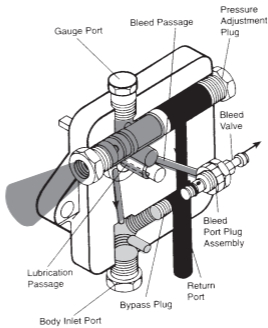

Fuel subject to vacuum

Fuel at atomization pressure

Fuel at return pressure

Specifications

Firing Capacity:

Recommended to 3 GPH fire size for pressures from 100 to 150 PSI with #1, #2 fuel oil, Kerosene, or Bio Fuel B100-B5 Bio Diesel

Gear Capacity:

25 GPH @ 100-150 PSI with #1, #2 fuel oil, Kerosene, or Bio Fuel. B100-B5 Bio Diesel.

Pressure:

Factory set at 100 PSI.

Adjustable to 150 PSI.

Inlet Requirements:

10" Hg maximum vacuum (approx. 10' vertical lift - exact distance will vary with tubing diameter and length). 3 psig maximum inlet pressure.

Speed:

3450 RPM.

Rotation: (As viewed from shaft end): Clockwise (D Style).

Porting:

- 1/8" NPTF, side located nozzle port.
- 1/8" NPTF, top located gauge port.
- 1/4" NPTF, bottom and cover located inlet ports and bottom located return port.
- Bypass plug accessible through the side located bleed port plug assembly.
- 3/8" flow through bleed valve.

Nozzle Location:

(As viewed from shaft end):

Clockwise (D Style) - Right side.

Shaft:

5/16" dia., 1.65" extension from mounting face, with keyless "D" drive.

Filter:

Self-cleaning rotary type.

Elastomers:

VITON shaft seal.

All other seals are VITON.

Mounting:

2 bolt flange - see interface dimensions.

Weight:

4 lbs., 2 oz., shipped oil-filled.

NOTE: To assure compliance with National Fire Protection Association Bulletin 31, "Installation of Oil Burning Equipment", fuel unit inlet pressure should not exceed 3 psig.

Dimensions

Dimensions in inches, () = cm

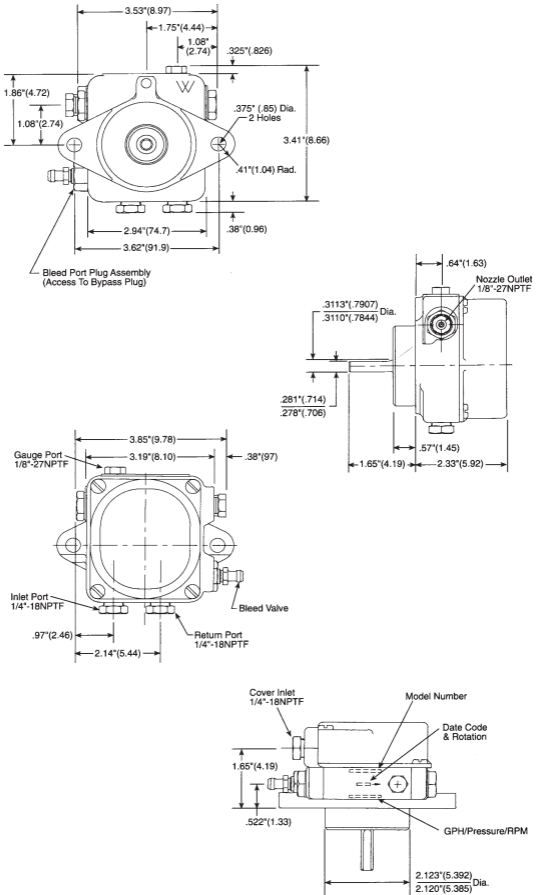

Waste Oil Pumps



Webster now has available a Mini waste oil pump. Webster's waste oil pumps are available in single stage models, rated at 15 gph for the SK41906 (3450rpm) and 20 gph for the SK41982 (1725rpm). Operating pressure is factory set at 100 psi. These waste oil pumps are able to maintain their recommended flow rates throughout the pressure range.

Inlet Requirements:

10" Hg maximum vacuum (approx. 10' vertical lift - exact distance will vary with tubing diameter and length). 3 psig maximum inlet pressure.

Speed:

1725 and 3450 RPM

Rotation: (As viewed from shaft end): Clockwise (D Style).

Porting:

- 1/8" NPTF, side located nozzle port.
- 1/8" NPTF, top located gauge port.
- 1/4" NPTF, bottom and cover located inlet ports and bottom located return port.
- Bypass plug accessible through the side located bleed port plug assembly.
- 3/8" flow through bleed valve.

Nozzle Location:

(As viewed from shaft end):
Clockwise (D Style) - Right side.

Shaft:

5/16" dia., 1.65" extension from mounting face, with keyless "D" drive.

Elastomers:

VITON shaft seal.

All other seals are VITON.

Mounting:

2 bolt flange - see interface dimensions.

Weight:

4 lbs., 2 oz., shipped oil-filled.

NOTE:

To assure compliance with National Fire Protection Association Bulletin 31, "Installation of Oil Burning Equipment", fuel unit inlet pressure should not exceed 3 psig.

<u>Single Stage</u>	<u>Location From Shaft End</u>	<u>RFS GPH</u>	<u>Rated PSI</u>	<u>Gear Set Capacity</u>
M17DN-15	CW/R	15	40	35
M17DN-6	CW/R	6	40	35
M34DN-3	CW/R	3	40	31
M34DN-3H	CW/R	3	150	31
M34DN-15	CW/R	15	40	35
2M34DN-15-H	CW/R	15	150	35
SK41906R	CW/R	14	100	27
SK41982R	CW/R	14	100	27

Dimensions:

Dimensions In Inches, () = cm

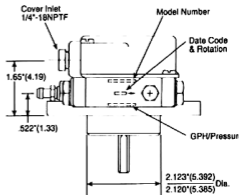
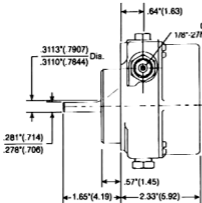
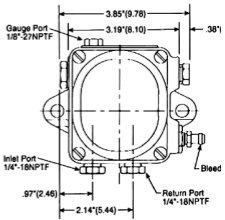
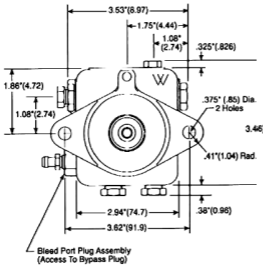

1RR SERIES

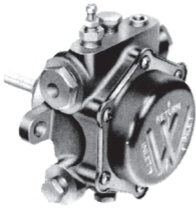

This single stage waste oil pump operates at 1725 rpm. The operating pressure range is 30-50 psi. Maximum inlet vacuum 10" Hg. Viscosity range is 34-7000 SUS (2.5 Centistokes), temperature range 40 F (min) - 160 F (max). This unit can be hub or flange mounted. The pump can be used on one or two pipe installations. Double lip type Viton seals assure low starting torque and provide positive protection from leaks. For waste oil and #4 or lighter fuel oils.

GENERAL SPECIFICATIONS

- Single Stage
- Single pipe operation only when used with thick oil.
- 1725 R.P.M.
- Operating pressure range 30-50 P.S.I.
- Viscosity range 34–7000 SUS (2.5-1500 Centistokes).
- Shaft seal and piston valve are Viton® material.
- Bypassing nozzle type.
- Power Requirements:
 - 1/4 H.P. for viscosity less than 1000 centistokes
 - 1/3 H.P. for viscosity greater than 1000 centistokes.
- Shaft Length is 3 1/8" long from mounting face to shaft end.
- Pump body has a flange and a hub.
- Maximum flow is 10-40 G.P.H. depending on model.

	<u>H.P.</u>	<u>Voltage</u>	<u>RPM</u>	<u>Rotation</u>	<u>GPH</u>	<u>Rated PSI</u>
SPM-25AT1RR140	1/4	120	1725	CW	10	45
SPM-25AT1RR243	1/4	120	1725	CW	20	45
SPM-25AT1RR244	1/4	120	1725	CW	40	45

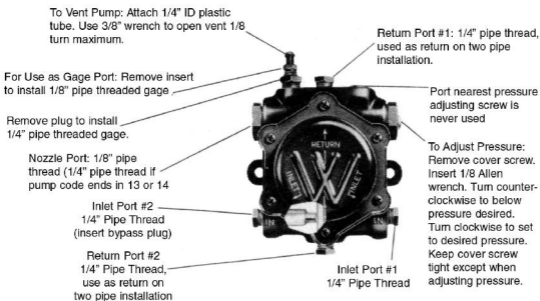

General Specifications

- Single Stage
- Single pipe operation only when used with thick oil.
- 1725 R.P.M.
- Operating pressure range 30-50 P.S.I.
- Viscosity range 34-7000 SUS (2.5-1500 Centistokes).
- Shaft seal and piston valve are Viton® material.
- Bypassing nozzle type.
- Power Requirements:

1/4 H.P. for viscosity less than 1000 centistokes

1/3 H.P. for viscosity greater than 1000 centistokes

- 3/8" Inlet Port
- 1/4" Discharge Port
- Shaft Length is 3 1/8" long from mounting face to shaft end.
- Pump body has a flange and a hub.
- Maximum flow is 10-40 G.P.H. depending on model.

WASTE - BIO OIL SAFETY VALVE

Oil Safety Valve for Bio applications. This valve is U/L listed for Bio Fuel and is compatible with a wide range of other fuels such as B20-B100, #1-#2 Fuel Oil, Diesel, Kerosene and Waste Oil. Temperature Range of -10 to 140 F.

Visit our Site...



Listed Webster
Oil Safety Valve for
BIO Fuel

H.P.	Voltage	RPM	Rotation	GPH	Rated PSI
1/4	120	1725	CW	10	45
1/4	120	1725	CW	20	45
1/4	120	1725	CW	40	45

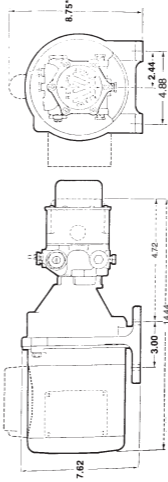
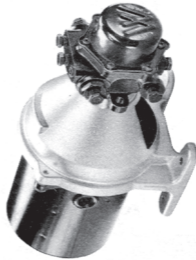

These units have the same characteristics as the 1RR models but incorporates a 120 volt, single phase, 1/4 hp motor.

R SERIES SERVICE SAVER FUEL UNITS

Available in both single-and two-stage models, Webster's service saver fuel units are rated to capacities of 80 gph. Featuring the unique Webster rotary filter, simple flange mounting, and an extended shaft length, the R Series is adaptable to virtually every replacement need.

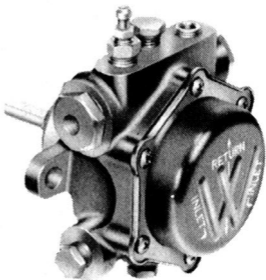

FUEL UNIT SPECIFICATIONS R Series Fuel Units Capacities to 80 gph Single- and Two-Stage Models

Capacities:

R Series models are rated to 80 gph at 100 psi with #2 fuel oil.

Pressure:

Built in pressure regulator.

Factory set at 100 psi (supply pumps set at 20 psi).

Speed:

1425,1725,2850 or 3450rpm.

Rotation:

Clockwise (D Style) or counterclockwise (C Style) when viewed from shaft end.

Porting:

1 /8" NPTF: side location nozzle port if pump code ends in 3 or 4.

1 /4" NPTF: side location nozzle port if pump code ends in 13 or 14.

1 /4" NPTF: 2 inlets, gauge port and top and bottom returns.

Shaft:

7/16 x up to 3.69" extension from mounting face, key drive.

Stepped shafts turned to 5/16" at coupling end.

Seal:

Double lip type.

Mounting:

Two bolt flange.

Filter:

Self cleaning rotary type - internal.

NOTE: External filter recommended with each installation.

Maximum Inlet Vacuum:

Single-stage units - 10" Hg

Two-stage units - 15" Hg

U.L. Listed to 72 gph:

To assure compliance with National Fire Protection Association's Bulletin 31, "Installation of Oil Burning Equipment," fuel unit inlet pressure should not exceed 3 psig.

SELECTION TABLE — SINGLE STAGE

Model	Type	Variable Dim "X"	Nozzle & Slotting Code	Nozzle Cutoff	Recommended Max. Fire Size		Rated Pressure	Maximum Wattage Requirement @Rated psi	Suction Gear Capacity
					@Rated psi	@100 psi			
1R Models: Single Stage 1725 RPM	1R111	3.13"	1,2 3	Yes	5 GPH 10 GPH	8 GPH 12 GPH	150PSI	60 Watts	20 GPH
	1R151	3.13"	1	Yes	8 GPH	8 GPH	100 PSI	50 Watts	20 GPH
	1R122	3.13"	3	Yes	12 GPH	15 GPH	300PSI	140 Watts	30 GPH
	1R162	3.13"	5,6,15	Yes	7 GPH	9 GPH	125 PSI	70 Watts	30 GPH
	1R213	3.75"	1	Yes	21 GPH	23 GPH	150 PSI	110 Watts	50 GPH
21R Models: Single Stage, 3450 RPM	21R150	3.13"	5	Yes	5 GPH	5 GPH	100 PSI	55 Watts	30 GPH
	21R211	3.13"	3	Yes	25 GPH	26 GPH	150PSI	105 Watts	45 GPH
	21R221	3.13"	3	Yes	21 GPH	26 GPH	300PSI	195 Watts	45 GPH

31R Models: Single Stage 1425 RPM	31R121	3.13"	4	Yes	4 GPH	9 GPH	300 PSI	90 Watts	20 GPH
41R Models: Single Stage, 2850 RPM	41R221	3.13"	14	No	18 GPH	22 GPH	300PSI	160 Watts	40 GPH
	41R221	3.13"	4	Yes	23 GPH	28 GPH	300PSI	225 Watts	55 GPH

*To Convert to horsepower, multiply watts X .0013410

SELECTION TABLE – SINGLE STAGE

Model	Type	Variable Dim "X"	Nozzle & Slotting Code	Nozzle Cutoff	Recommended Max. Fire Size		Rated Pressure	Maximum Wattage Requirement @Rated psi	Suction Gear Capacity
					@Rated psi	@100 psi			
1R Models: Single Stage 1725 RPM	1R111	3.13"	1,2 3	Yes	5 GPH 10 GPH	8 GPH 12 GPH	150PSI	60 Watts	20 GPH
	1R151	3.13"	1	Yes	8 GPH	8 GPH	100 PSI	50 Watts	20 GPH
	1R122	3.13"	3	Yes	12 GPH	15 GPH	300PSI	140 Watts	30 GPH
	1R162	3.13"	5,6,15	Yes	7 GPH	9 GPH	125 PSI	70 Watts	30 GPH
	1R213	3.75"	1	Yes	21 GPH	23 GPH	150 PSI	110 Watts	50 GPH
21R Models: Single Stage, 3450 RPM	21R150	3.13"	5	Yes	5 GPH	5 GPH	100 PSI	55 Watts	30 GPH
	21R211	3.13"	3	Yes	25 GPH	26 GPH	150PSI	105 Watts	45 GPH
	21R221	3.13"	3	Yes	21 GPH	26 GPH	300PSI	195 Watts	45 GPH

2R223	4.25"	4	No	30 GPH	—	300 PSI	210 Watts	70 GPH
2R253	4.25"	14	No	30 GPH	30 GPH	100 PSI	100 Watts	70 GPH
2R283	4.25"	4	No	30 GPH	—	80 PSI	90 Watts	70 GPH
2R343	4.25"	13	No	34 GPH	—	45 PSI	70 Watts	70 GPH
2R616	5.75"	13, 14	No	62 GPH	66 GPH	150 PSI	245 Watts	125 GPH
2R626	5.75"	14	Np	50 GPH	66 GPH	300 PSI	410 Watts	125 GPH
2R636	5.75"	4	No	72 GPH	—	20 PSI	105 Watts	125 GPH
2R656	5.75"	14	No	66 GPH	66 GPH	100 PSI	195 Watts	125 GPH
2R686	5.75"	4	No	65 GPH	—	80 PSI	175 Watts	125 GPH
2R618	5.75"	14	No	75 GPH	80 GPH	150 PSI	325 Watts	125 GPH
2R628	5.75"	14	No	60 GPH	80 GPH	300 PSI	535 Watts	125 GPH

*To Convert to horsepower, multiply watts X .0013410

SELECTION TABLE – TWO-STAGE (CONT.)

Model	Type	Variable Dim "X"	Nozzle & Slotting Code	Nozzle Cutoff	Recommended Max. Fire Size		Rated Pressure	Maximum Wattage* @Rated psi	Suction Gear Capacity
					@Rated psi	@100 psi			
22R Models:									
Two Stage									
3450 RPM									
	22R210	3.75"	3	Yes	15 GPH	15 GPH	150 PSI	90 Watts	45 GPH
	22R220	3.75"	3 14	Yes No	12 GPH 14 GPH	15 GPH 15 GPH	300 PSI	145 Watts	45 GPH
	22R250	3.75"	5	Yes	5 GPH	5 GPH	100 PSI	70 Watts	45 GPH
	22R211	3.75"	3,4 14	Yes No	25 GPH 26 GPH	26 GPH 27 GPH	150 PSI	130 Watts	70 GPH
	22R221	3.75"	3 14	Yes No	21 GPH 23 GPH	26 GPH 27 GPH	300 PSI	220 Watts	70 GPH
	22R322	4.25"	14	No	34 GPH	40 GPH	300 PSI	300 Watts	105 GPH
	22R613	4.75"	13	No	63 GPH	65 GPH	150 PSI	260 Watts	135 GPH
	22R623	4.75"	14	No	56 GPH	65 GPH	300 PSI	425 Watts	135 GPH

32R Models:	32R111	3.75"	3	Yes	8 GPH	9 GPH	150 PSI	65 Watts	30 GPH
Two Stage 1425 RPM	32R121	3.75"	3,4	Yes	4 GPH	9 GPH	300 PSI	105 Watts	30 GPH
	32R213	4.25"	3	Yes	23 GPH	25 GPH	150 PSI	115 Watts	60 GPH
	32R223	4.25"	4	Yes	14 GPH	25 GPH	300 PSI	180 Watts	60 GPH
	32R626	5.75"	14	No	36 GPH	51 GPH	300 PSI	345 Watts	105 GPH
42R Models:	42R120	3.75"	4	Yes	9 GPH	13 GPH	300 PSI	120 Watts	40 GPH
Two Stage 2850 RPM	42R211	3.75"	3	Yes	20 GPH	21 GPH	150 PSI	110 Watts	60 GPH
	42R221	3.75"	3,4	Yes	17 GPH	21 GPH	300 PSI	180 Watts	60 GPH
	42R613	4.75"	14	No	47 GPH	48 GPH	150 PSI	220 Watts	110 GPH
	42R623	4.75"	14	No	44 GPH	48 GPH	300 PSI	360 Watts	110 GPH
	42R624	4.75"	14	No	65 GPH	74 GPH	300 PSI		
	42R626	5.75"	14	No	72 GPH	84 GPH	300 PSI		

NOTES:

Oil burner nozzles are rated at 100 psi. Any increase in fuel unit pressure over 100 psi will increase the fire size above nozzle rating. To assure compliance with NFPA's Bulletin 31, "Installation of Oil Burning Equipment," fuel unit pressure should not exceed 3 psig.

*To Convert to horsepower, multiply watts X .0013410

R SERIES FUEL UNITS – CODE ANALYSIS

TYPICAL CODE – **IR I I I D – I A 3**
T T T T T T T T T
A B C D E F G H J

- A**
- 1R - Single Stage -1725 RPM
 - 21R - Single Stage -3450 RPM
 - 2R - Two Stage -1725 RPM
 - 22R - Two Stage -3450 RPM
 - 31R - Single Stage -1425 RPM
 - 41R - Single Stage -2850 RPM
 - 32R - Two Stage -1425 RPM
 - 42R - Two Stage -2850 RPM

- F**
- Bypass Plug Access
 - Left hand inlet (from front)

- B**
- Number of Filter Sections
 - 1 thru 6

- G**
- Design Series
 - Shaft Seal Type
 - Face Lip

- C**
- Max Rated Pressure (PSI)

- 1 4 1 stage or 2 stage w/suction gear same size as pressure gear.
- 3 5 2 stage w/suction gear one size larger than pressure gear.

Code	Max. Pres.	Factory Set At
1	150 PSI	100 PSI
2	300 PSI	100 PSI
3	20 PSI	10 PSI
4	45 PSI	40 PSI
5	100 PSI	100 PSI
6	125 PSI	100 PSI
8	80 PSI	20 PSI

- H**
- Special Customer Modifications

- D**
- Pressure Gear Size 0 thru 8

- J**
- Nozzle Outlet Type and Bypass Condition. Final digit even - Factory set for 2-pipe operation. Final digit odd - Factory set for one pipe operation.

- E**
- Rotation and Porting- As viewed from Shaft End
 - A Clockwise Nozzle Port Left
 - B CCW Nozzle Port Right
 - C CCW Nozzle Port Left
 - D CW Nozzle Port Right

- Pumps ending in 3 internal cut-off
- Pumps ending in 14 no internal cut-off

Rotation and Nozzle Location

R Series Fuel Units are available in standard C Style models (counterclockwise rotation, nozzle port on left, as viewed from shaft end) or D Style models (clockwise rotation, nozzle port on right, as viewed from shaft end).

Some special models are available with A Style porting (clockwise rotation, nozzle port on left) and B Style porting (counterclockwise rotation, nozzle port on right) Consult Sales Department for availability.

FUEL UNITS (CROSS REFERENCE)

Webster Model No.	Suntec Model No.
21R150D*4A5	JA2BB-100
21R150D*4A5	JA2BB-300
21R150D*4A5	JB2BB-100
21R150D*4A5	JJ2BB-300
21R221D-4C3	J2BA-100
21 R221D-4C3	J2BB-100
1R162D*4BK5/21 R150D*4A5	J2BB-300

FUEL-UNITS (CROSS REFERENCE) (Cont.)

Webster Model No.	Suntec Model No.
21R221C-4C3	J2BC-100
21R221D-4C3	J3BA-100
21R221D-4C3	J3BA-B100
21R221D-4C3	J3BB-100
21R221D-4C3	J3BB-200
21R221C-4C3	J3BC-100
21R221C-4C3	J3BC-200
21R221C-4C3	J3BC-179
21R221C-4C3	J3BC-408
21R221C-4C3	J3BD-100
1R122D-4C3 (1725only)	J4PB-100
1R122C-4C3 (1725only)	J5BC-313H
1R122C-4C3 (1725only)	J5BC-D317
22R220D-5C3	HA2BB-100
22R220D-5C3	HA2BB-300
22R211D-5C3	H2BB-100
22R211D-5C3	H2BB-300
22R211C-5C3	H2BC-412
22R211D-5C3	H2PB-100
22R211D-5C3	H3BA-100
22R211D-5C3	H3BA-200
22R211D-5C3	H3BA-B200H
22R211D-5C3	H3BB-100
22R211D-5C3	H3BB-200
22R211C-5C3	H3BC-100
22R221C-5C3	H3BC-C200H
22R211C-5C3	HBBD-200
22R211D-5C3	H3PA-100
22R221D-5C14	H3PAN-C150H
22R221D-5C3	H3PB-B100
22R221D-5C14	H3PBN-C254H
22R322D-5C14	H4PA-200
22R221D-5C3	H4PAN-C131H
22R221D-5C14	H4PAN-C251H
22R221C-5C3	H4PC-C200H
22R623D-5C14	H5PA-200
22R623D-5C14	H5PB-100
2R121D-5C3	H6PA-C100
22R623D-5C14	H6PA-200
22R623C-5C14	H6PC-C200H
22R623C-5C14	H6PC-C253H
2R628C-4C14	H8KCN-C200
2R618D-4C14	H8PB-200

INSTALLATION DATA

R Series units may be used in one- or two-pipe installations. Two-pipe operation is recommended for all high capacity units. A yellow tag is attached to units that are factory set for two-pipe installation.

NOTE: Inlet ports #1 and #2, and return port #2 are 3/8" pipe thread on high capacity units. (2R6-8 Series.)

Unit shown at the right has a left side by-pass plug access, (-) in the sales code. (*) in the code designates right hand access as shown below.



Inlet Port #1: 1/4" pipe thread

Return Port #2: 1/4" pipe thread, used as return on two pipe installation

To Vent Pump: Attach 1/4" ID plastic tube. Use 3/8" wrench to open vent 1/8 turn maximum.

For Use as Gauge Port: Remove insert to install 1/8" pipe threaded gauge.

Remove plug to install 1/4" pipe threaded gauge.

Nozzle Port: 1/8" pipe thread (1/4" pipe thread if pump code ends in 13 or 14)

Inlet Port #2
1/4" Pipe Thread
"Insert - (Bypass Plug 1/8 pipe thread)"
P/N 29533-35 3/16 Allen

Return Port #2
1/4" Pipe Thread,
use as return on
two pipe installation

Return Port #1: 1/4" pipe thread, used as return on two pipe installation.

Port nearest pressure adjusting screw is never used

To Adjust Pressure:
Remove cover screw.
Insert 1/8 Allen wrench. Turn counter-clockwise to below pressure desired.
Turn clockwise to set to desired pressure.
Keep cover screw tight except when adjusting pressure.

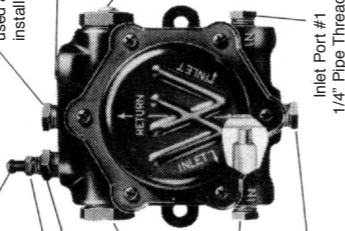

BODY STYLE D
CLOCKWISE ROTATION

BODY STYLE C
COUNTERCLOCKWISE ROTATION (CCW)
OPPOSITE OF THAT PICTURED

One-Pipe Installation

Recommended only when bottom of tank is above fuel unit, unless pump code ends in 15.

1. Remove BYPASS PLUG if installed, through applicable INLET PORT.
2. Connect inlet line to preferred INLET PORT and NOZZLE PORT to NOZZLE SYSTEM.
3. Plug all unused ports securely.
4. Start burner and bleed all air from the system by opening VENT PLUG. Close VENT securely when oil flow in tube is clear, if pump is equipped with special vent plug. Secure GAUGE PORT PLUG on units not so equipped when oil appears leaking out.

Two-Pipe Installation

1. Insert BYPASS PLUG if not installed, through applicable INLET PORT.
2. Connect inlet line to preferred INLET PORT and NOZZLE PORT to NOZZLE SYSTEM
3. Connect return line to preferred RETURN PORT.
4. Plug all unused ports securely.
5. Start burner. Two-stage pumps will self-vent. If single stage and code ends in 3 or 4, bleed all air from system by opening VENT PLUG. Close VENT securely when oil flow in tube is clear, if pump is equipped with special vent plug. Secure GAUGE PORT PLUG on units not so equipped when oil appears leaking out.

Mounting for One-Pipe Systems

Gravity Feed Systems (Diagram A)—Fuel units may be mounted in any position including shaft up and shaft down. See Positions 1 through 4.

Non-Gravity Feed Systems (Diagram B) — R Series Fuel Units may *only* be mounted upright, Position 1; or rotated 90° with nozzle down, Position 2. Other mounting positions are not recommended.

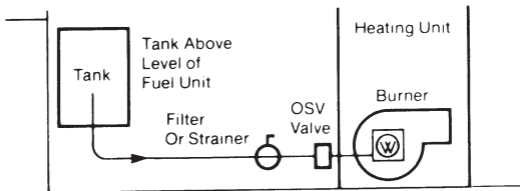

DIAGRAM A - ONE PIPE, GRAVITY FEED SYSTEM

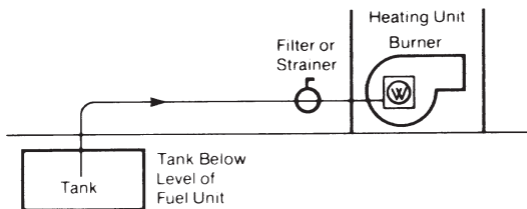

DIAGRAM B - ONE PIPE
NON-GRAVITY FEED SYSTEM

Mounting for Two-Pipe Systems

Fuel units may be mounted in any position including shaft up and shaft down. See Positions 1 through 4.

Illustrations show port locations for C Style units (counterclockwise rotation); D Style units (clockwise rotation) are the opposite of that pictured.

Installation diagrams shown for reference only. Compliance to applicable codes is the responsibility of installer.

POSITION 1
**Upright,
Nozzle Right:**

**All One pipe or
Two Pipe Systems**

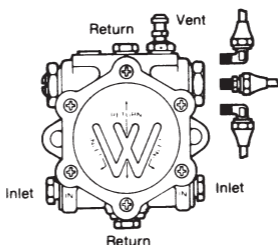

POSITION 2
**Rotated 90°
Nozzle Down:**

**All One Pipe or
Two Pipe Systems**

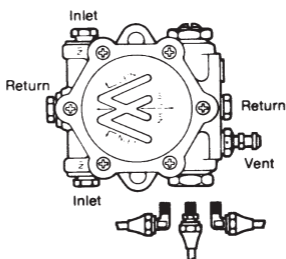

POSITION 3
**Rotated 180°
Nozzle Left:**

**All Two Pipe Systems,
or One Pipe Gravity
Feed Systems Only**

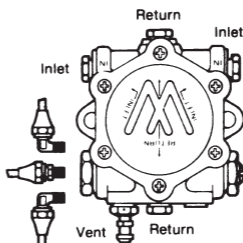

POSITION 4
 Rotated 270°
 Nozzle Up:

All Two Pipe Systems,
 or One Pipe Gravity
 Feed Systems Only

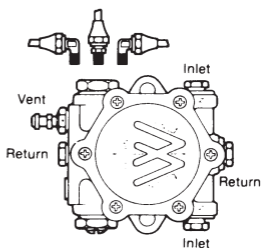

Replacing A Style and B Style Units

Discontinued A Style and B Style R Series fuel units can be replaced with minimal changes in most installations. Fuel unit model code numbers and rotation arrows are stamped on the top of the body casting.

In *two-pipe systems* and in *one-pipe, gravity feed systems*, current C Style and D Style units can be mounted in any position to facilitate easiest piping.

In *one-pipe, non-gravity feed systems* (where the mounting positions are limited), an extra length of pipe or tubing must be connected to the nozzle line to reach the fuel unit nozzle port. See previous page for permitted mounting positions.

Preferred installation calls for use of flare tube fittings on all I connections. Be certain all plugs and connections are secure and leak-tight.

Body Styles
 A (CW) & C (CCW)
 (LH Nozzle, Viewed
 From Shaft End)

Body Styles
 B (CCW) & D (CW)
 (RH Nozzle, Viewed
 From Shaft End)

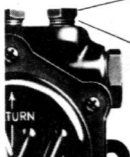

To Vent Pump:
 Loosen Gauge Port Plug

For Use as Gauge Port:
 Remove Plug to install
 1/4" Pipe Threaded Gauge



Pumps Without
 Special Vent Fitting

Typical Replacement Installations

Replace A Style units (clockwise rotation, nozzle port on left, as viewed from shaft end) with D Style units (clockwise rotation, nozzle port on right, as viewed from shaft end).

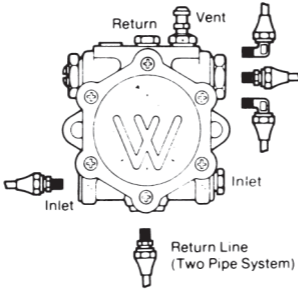

Standard A Style Installation: One or Two Pipe System

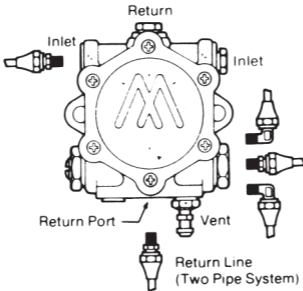

Replacement with D style, Rotated 180°: One Pipe, Gravity Feed System: or Two Pipe System

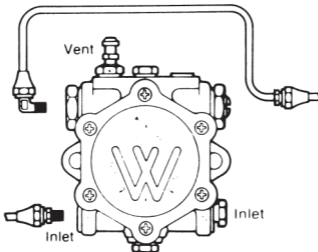

Replacement with D style, Nozzle Line Extended: One Pipe, Non-Gravity Feed System

Replace B Style units (counterclockwise rotation, nozzle port on right, as viewed from shaft end) with C Style units (counterclockwise rotation, nozzle port on left, as viewed from shaft end).

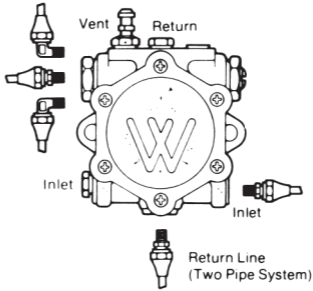

**Standard B Style Installation:
One or Two Pipe System**

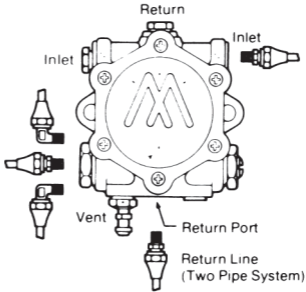

**Replacement with C style,
Rotated 180°: One Pipe, Gravity
Feed System: or Two Pipe System**

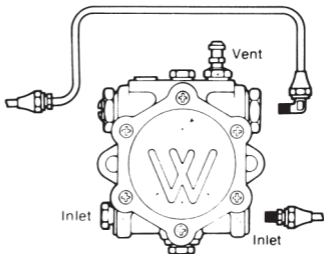

**Replacement with C style,
Nozzle Line Extended: One Pipe,
Non-Gravity Feed System**

IMPORTANT: Do not loosen or try to tighten any pump plugs not to be used in the installation. NON-HARDENING OIL PIPE DOPE IS RECOMMENDED for use on the threads of all fittings. Paste must be used with care to prevent deposits on critical internal areas of the pump damage. Do not use teflon tape. EVIDENCE OF TEFLON TAPE USE WILL BE CAUSE TO VOID WARRANTY.

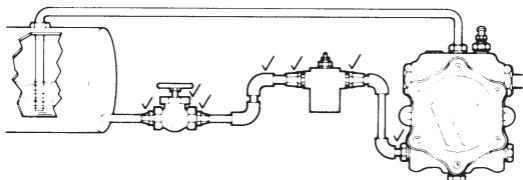

Installation Notes:

If the pump doesn't work, check for air leaks.

If you're experiencing the following problems; poor cutoff, noisy operation, erratic fire, check for air leaks.

Return line must be submerged

Check all fittings

Check all joints

Check optional inlet plugs

DO NOT use compression fittings

90% of start-up problems are due to air leaks in the suction line . . . so check and double check for air leaks.

"Fuel unit inlet pressures should not exceed 3 psig in order to comply with National Fire Protection Association's Bulletin 31."

Nozzle port pressure at cutoff is not less than 80% of set pressure unless unit has blank nozzle or pump code ends in 13 or 14 (no cutoff).

To assure maximum performance, INLET VACUUM, measured at unused INLET PORT, should not exceed 10" Hg on single-stage pumps or 15" Hg on two-stage pumps.

1R00 SERIES SINGLE-STAGE TRANSFER PUMPS

BODY STYLE C & D

Rated at capacities up to 66 gph at 100 psi, the 1R00 Series features the versatility of the R Series design. With 2 inlet ports, 4 discharge ports, and 1 gauge/vent port, the 1R00 Series can fit virtually all installations.

FUEL UNIT SPECIFICATIONS

Single-Stage Transfer Pumps

1R00 Series Pumps

Capacities:

1R003-4EH—31 gph at 100 psi

1R004-4EH, 4EG—43 gph at 100 psi

1R006-4EH—66 gph at 100 psi.

Pressure:

No internal pressure regulator.

Speed:

Rated at 1725 rpm.

Rotation:

D Style—Clockwise when viewed from shaft end.

C Style—Counterclockwise when viewed from shaft end.

Porting:

1/4" NPTF: gauge/vent port, 2 inlets and 4 discharge ports.

Shaft:

7/16" diameter, key drive.

EH units have 1-7/8" shaft extension from mounting face. EG unit has 3-1/8" shaft extension from mounting face with outboard ball bearing.

Seal:

Double lip type.

Mounting:

Hub or two bolt flange mount.

Filter:

No internal filter. External filter recommended.

Maximum Inlet Vacuum:

10" Hg.

U.L. Listed:

To assure compliance with National Fire Protection Association's Bulletin 31, "Installation of Oil Burning Equipment," fuel unit inlet pressure should not exceed 3 psig.

Operation

The 1R00 Series pumps do not incorporate an internal regulating valve or filter. They are intended for transfer use up to 100 psi and must not be operated with blocked outlet. Use one-pipe installation only and do not remove bypass plug.

For maximum performance inlet vacuum, when measured at unused inlet port, should not exceed 10" Hg.

Do not use less than 3/8" OD tubing for lines. Size per gearset capacity shown below:

SELECTION TABLE

Model	100 psi Rating	Gearset Capacity
Ratings for No. 2 Fuel Oil		
1 R003-4EH	31 gph	48 gph
1R004-4EH, 4EG	43 gph	66 gph
1 R006-4EH	66 gph	95 gph

1ROO Series units are rated for 1725 rpm and may be hub or flange mounted. Standard EH units have 1-7/8" shaft extension. EG units 3-1/8" shaft extension, plus out-board ball bearing.

R SERIES FUEL UNITS — CODE ANALYSIS

TYPICAL CODE— **IR I I I D . I A 3**
T T T T T T T T T
A B C D E F G H J

- A**
 - 1R - Single Stage -1725 RPM
 - 21R - Single Stage -3450 RPM
 - 2R - Two Stage -1725 RPM
 - 22R - Two Stage -3450 RPM
 - 31R - Single Stage -1425 RPM
 - 41R - Single Stage -2850 RPM
 - 32R - Two Stage -1425 RPM
 - 42R - Two Stage -2850 RPM
- B**
 - Number of Filter Sections
 - 1 thru 6
- C**
 - Max Rated Pressure (PSI)

	Max	Factory
Code	Pres	Set At
1	150 PSI	100 PSI
2	300 PSI	100 PSI
3	20 PSI	10 PSI
4	45 PSI	40 PSI
5	100 PSI	100 PSI
6	125 PSI	100 PSI
8	80 PSI	20 PSI
- D**
 - Pressure Gear Size 0 thru 8
- E**
 - Rotation and Porting-
 - As viewed from Shaft End
 - A Clockwise Nozzle Port Left
 - B CCW Nozzle Port Right
 - C CCW Nozzle Port Left
 - D CW Nozzle Port Right
- F**
 - Bypass Plug Access
 - * Right hand inlet (from front cover)
 - Left hand inlet (from front)
- G**
 - Design Series
 - Shaft Seal Type
 - Face Lip
- H**
 - Special Customer Modifications
- J**
 - Nozzle Outlet Type and Bypass Condition. Final digit even - Factory set for 2-pipe operation. Final digit odd - Factory set for one pipe operation.

Rotation and Nozzle Location

R Series Fuel Units are available in standard C Style models (counterclockwise rotation, nozzle port on left, as viewed from shaft end) or D Style models (clockwise rotation, nozzle port on right, as viewed from shaft end).

Dimensions

Drawing shows gauge port location for D Style units. C Style units are the opposite of that pictured.

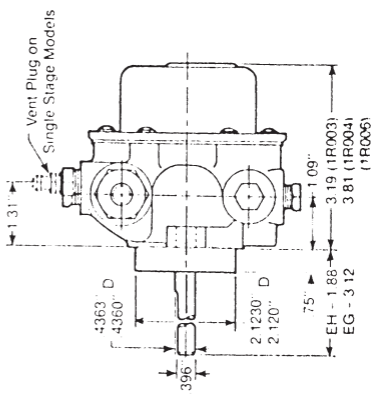
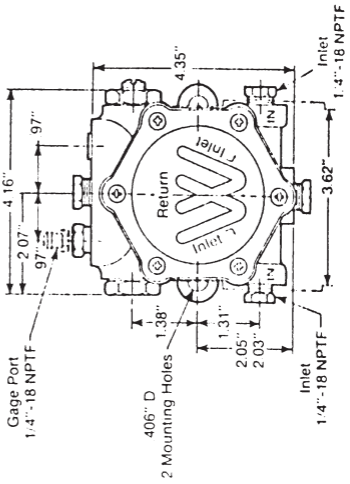
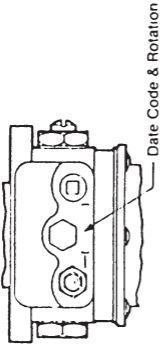

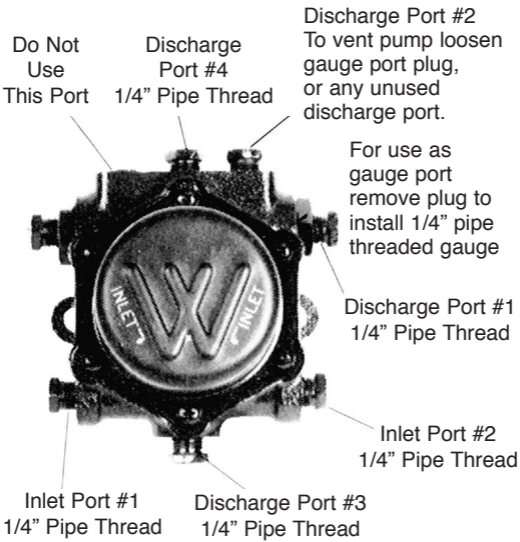

BODY STYLE C



“C” ROTATION DIRECTION

BODY STYLE D

**“D” ROTATION DIRECTION
OPPOSITE OF THAT PICTURED
(See rotation arrow on top
of pump to confirm shaft
rotation direction)**

INSTALLATION DATA

1. Connect preferred inlet to tank through suitable line filter.
2. Connect preferred discharge port to external regulator or distribution system.
3. For initial priming it is desirable to loosen the gauge port or any unused discharge port to bleed air from the supply line and pump. Tighten the plug securely when oil flows clear.

Failure to prime pump may be due to “dry pump” conditions. Remove vent plug and fill pressure cavity slowly to allow oil to “wet” the gears.

4. Be certain all plugs and connections are secure and leak-tight

Checking for Air Leaks

Be certain all plugs, fittings and joints are secure and airtight. Many problems in fuel unit installations result from air leaks in the suction line.

Measure inlet vacuum during operation at an unused inlet port. An abnormally low vacuum reading may indicate an air leak. Generally, assume 0.75 inch of vacuum for every foot of vertical lift, plus frictional tubing losses and other in-line restrictions.

V SERIES HIGH DELIVERY FUEL PUMPS

The V Series is designed to meet the high delivery requirements of commercial, industrial, and institutional systems with a minimum of mechanical and hydraulic noise. Single-stage models can provide a firing rate up to 270 gph at up to 10" Hg inlet vacuum. Two-stage firing rates are as high as 205 gph up to 15" Hg inlet vacuum. Field adjustable integral regulating valves factory pre-set for 100 and 150 psi operation are offered as an option to meet specific system requirements.

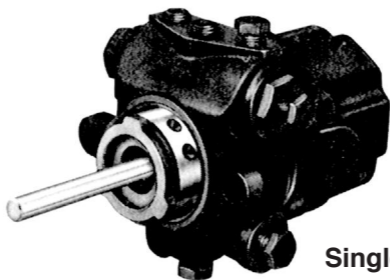

Single Stage

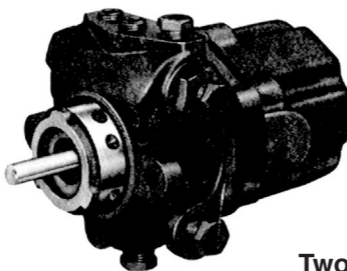

Two Stage

FUEL UNIT SPECIFICATIONS

Single- and Two-Stage Fuel-Units

V Series

High Capacity Fuel and Transfer Pumps

Capacities:

Single-stage units: up to 180 gph with #2 oil, to 270 gph with 1000 SSU oil.

Two-stage units: up to 145 gph with #2 oil, to 205 gph with 1000 SSU oil

NOTE: See rating table for capacity at specific pressure and rpm

Pressure:

V02: Rated pressure 300 psi—factory set at 150 psi.

V05: Rated pressure 100 psi—factory set at 100 psi.

V08: Rated pressure 80 psi—factory set at 20 psi.

V00: No internal regulation.

Speeds:

1725 or 3450 rpm.

Rotation:

D Style—clockwise when viewed from shaft end.

C Style—counter clockwise when viewed from shaft end.

Porting:

1/4" NPTF: gauge/optional nozzle port, nozzle port.

3/8" NPTF: return port, 2 optional inlets.

1/2" NPTF: inlet in cover

Shaft:

DM Style—7/16" x 3.5" extension from mounting face.

DO Style—7/16" x 1.88" extension from mounting face.

Seal:

Double lip type.

Mounting:

Hub or two bolt flange mount.

Filter:

No internal filter.

External Line filter recommended.

Maximum Inlet Vacuum:

Single-stage units: 10" Hg

Two-stage units: 15" Hg

U.L. Listed

SELECTION TABLE

NOTE: Max. Recommended Firing Rates apply at 10" Hg for single-stage units and 15" Hg for two-stage units

	Inlet Line Sizing																				
	Max. Recomd. Firing Rate gph		Max. Recomd. Firing Rate gph		Gear Set Capacity gph		Recommended Motor h.p.			Dim. A											
	1725	3450	1725	3450	1725	3450	1725	3450	1725	3450	1725	3450	1725	3450	1725	3450	1725	3450	1725	3450	
V05 & V02 Series Single-Stage Fuel Pumps (with Internal Regulations)																					
100 psi Ratings	V052_-4D_20	40	75	65	135	65	135	65	135	65	135	.25	.33	.25	.75	.75	.25	.75	.25	.75	5.13
	V056_-4D_20	130	--	190	--	190	--	190	--	190	--	.50	--	.50	--	.75	--	.75	--	.75	5.13
300 psi Ratings	V022_-4D_20	20	60	50	120	50	120	50	120	50	120	.50	.75	.50	1.0	.50	.50	1.0	.50	1.5	5.13
	V023_-4D_20	40	105	80	185	80	185	80	185	80	185	.50	1.00	.50	1.5	.75	.75	2.0	.75	2.0	5.13
	V024_-4D_20	60	140	110	240	110	240	110	240	110	240	.75	1.5	.75	2.0	1.5	2.0	1.5	2.0	2.0	5.13
	V026_-4D_20	95	--	155	--	155	--	155	--	155	--	1.0	--	1.0	--	1.0	--	1.0	--	1.0	5.13
	V028_-4D_20	115	--	190	--	190	--	190	--	190	--	1.5	--	2.0	--	2.0	--	2.0	--	2.0	5.67
300 psi Ratings	2V022_-5D_20	20	60	50	120	100	205	100	205	100	205	.50	1.0	.50	1.5	.50	.50	1.5	.50	2.0	5.67
	2V023_-5D_20	40	105	80	185	140	270	140	270	140	270	.75	1.5	.75	2.0	.75	.75	2.0	.75	2.0	6.17
	2V024_-5D_20	60	--	110	--	200	--	200	--	200	--	.75	--	1.0	--	1.0	--	1.0	--	1.0	6.71
	2V026_-5D_20	95	--	155	--	250	--	250	--	250	--	1.5	--	1.5	--	1.5	--	1.5	--	1.5	7.75

V00 Series Single-Stage transfer (with no internal Regulation)

20 psi Ratings*	V002_-4D_	45	85	70	140	70	140	.25	.25	.25	.25	.50	5.13
	V003_-4D_	70	140	100	205	100	205	.25	.25	.25	.25	.75	5.13
	V004_-4D_	95	175	140	270	140	270	.25	.25	.25	.25	.75	5.13
	V006_-4D_	145	—	200	—	200	—	.25	—	.50	—	—	5.13

V08 Series Single-Stage Transfer Pumps (with Internal Regulation)

80 psi Ratings*	V086_-4D_20	135	—	190	—	250	—	.33	—	.75	—	—	7.75
-----------------	-------------	-----	---	-----	---	-----	---	-----	---	-----	---	---	------

2V00 Series Two-Stage Transfer Pumps (with no Internal Regulation)

20 psi Ratings**	2V006_-5D_	145	—	200	—	250	—	.33	—	.75	—	—	7.75
------------------	------------	-----	---	-----	---	-----	---	-----	---	-----	---	---	------

2V08 Series Supply Pumps (with Internal Regulation)

80 psi Ratings**	2V086_-5D_4	135	—	190	—	250	—	.50	—	1.0	—	—	7.75
------------------	-------------	-----	---	-----	---	-----	---	-----	---	-----	---	---	------

* Operating pressure to 300 psi permissible (using external regulating valve)

V00 Series gph and hp ratings at 100 psi same as V05 ratings above.

V00 Series gph and hp ratings at 300 psi same as V02 ratings above.

** Operating pressure to 300 psi permissible (using external regulating valve)

2V00 Series gph and hp ratings at 300 psi same as V02 ratings above.

Available in CW and CCW rotation.

V SERIES CODE ANALYSIS

HARDENED GEARS — H J71—MFG. DATE CODE

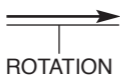

VO	2	6	C	1	00	30
T	T	T	T	T	T	T
A	B	C	D	E	F	G

A

Pump Series

VO—Single-Stage

2VO—Two-Stage

B

Pressure Code	Rated Pressure (psi)	Typ. Adj. Range (psi)
0	No Valve	—
5	100	85-120
2	300	125-330
8	80	15-85

C

Gear Size Code	Nom. Thickness
2	1/4
3	3/8
4	1/2
6	3/4
8	1

D

Body Style	Rotation	Nozzle
C	CCW	Left
D	CW	Right

NOTE: Nozzle location and shaft rotation determined viewing unit from shaft end.

E.

No.	Design Series
1	Initial Design
3	2-Stage, Inlet Gear One Size Larger than Pressure Gear
4	Single-Stage, Seal Pressed in Body
5	Same as 3 Ex. Seal Pressed/Body

F.

Cust. Code	Shaft Ext.
DM	3-1/2
DO	1-7/8

G

Pump Operation
V-Guide, One Slot, No Cutoff
No Number for Transfer Pumps

Rotation and Nozzle Location

V Series Fuel-Units are available in standard C Style Models (counterclockwise rotation, nozzle port on left, as viewed from shaft end) or D Style Models (clockwise rotation, nozzle port on right, as viewed from shaft end).

Dimensions

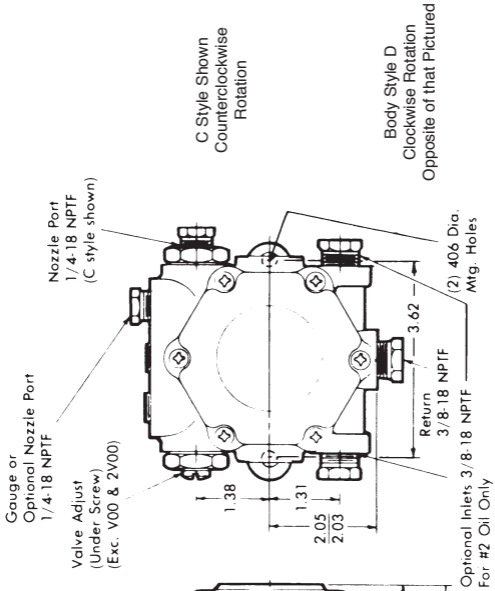

Nozzle Location & Shaft Rotation
 (As viewed from shaft end)

Nozzle	Rotation
'C' Style Left	CCW
'D' Style Right	CW

INSTALLATION DATA

V Series pumps are shipped from the factory set for two-pipe operation. They are not recommended for use in one-pipe systems (except series V00, see Note 1).

IMPORTANT: Do not loosen or try to tighten any pump plugs not to be used in the installation. **NON-HARDENING OIL PIPE DOPE IS RECOMMENDED** for use on the threads of all fittings. Teflon tapes or paste must be used with care to prevent depositing tape pieces or fibers into critical internal areas of the pump. Reduced torques must be used with teflon materials to avoid thread or casting damage. **EVIDENCE OF TEFLON MATERIAL IN INTERNAL AREAS OF THE FUEL-UNIT WILL BE CAUSE TO VOID WARRANTY.**

V00, 2V00 SERIES WITH NO INTERNAL REGULATION

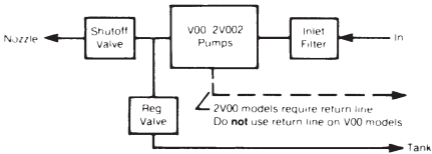

V0, 2V0 SERIES WITH INTERNAL REGULATION

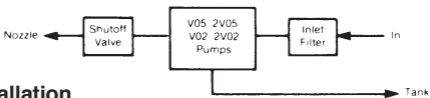

Installation

1. Connect inlet line to preferred INLET PORT. Use of inlet in cover is recommended for minimum inlet vacuum loss. Connect nozzle line to nozzle port.
2. Connect return line to preferred RETURN PORT except on V00 pumps. Use of bottom return is recommended to minimize back pressure. Top return port not recommended for oil heavier than #2.
3. Plug all unused ports securely.
4. Start burner. Two-stage and most one-stage pumps will self-vent. V00 with shut-off valve in nozzle line may have to be vented manually by loosening GAGE PORT plug. Tighten plug securely when oil flows clear.

Installation Notes:

“Fuel unit inlet pressures should not exceed 3 psig in order to comply with National Fire Protection Association’s Bulletin 31.”

To assure maximum performance, INLET VACUUM, measured at unused INLET PORT, should not exceed 10” Hg on single-stage pumps or 15” Hg on two-stage pumps.

NOTE: Max Recommended Firing Rates apply to 10” Hg for single-stage units and 15” Hg for two-stage units.

**Body Style D
Clockwise Rotation (CW from Shaft End)**

**Body Style C
Counterclockwise Rotation (CCW from Shaft End)**

Gage Port, 1/4" Pipe Thread
Optional Return Port,
1/4" Pipe Thread

Port Nearest Pressure
Adjust Plug Is Not Used

To Adjust Pressure: (Except
2V00 & V00 Series. See Note 1.)
Remove cover screw. Insert 1/8"
Allen wrench. Turn counter-
clockwise to below pressure
desired. Turn clockwise to set
desired pressure. Keep cover
screw tight except when adjust-
ing pressure.

Cover Inlet Port
1/2-14 Pipe Thread

Inlet Port #2
3/8" Thread

Return Port, 3/8" Pipe Thread
Connect as Shown Below

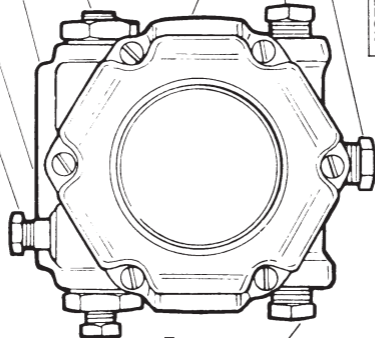

Nozzle Port
1/4" Pipe Thread

Inlet Port #1
3/8" Pipe Thread

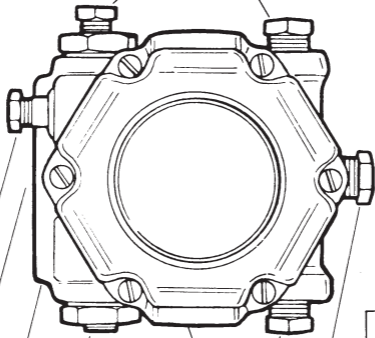

Nozzle Port
1/4" Pipe Thread

Inlet Port #1
3/8" Pipe Thread

NOTE 1: Do not connect return line to V00 Series pump. Keep both return ports plugged. V00 and 2V00 do not have internal regulation. Use external regulation if required. Return line **must** be connected to 2V00 models.

B SERIES FUEL OIL TRANSFER PUMPS

B Series transfer pumps are designed to provide efficient pumping of #1 to #6 fuel oils in capacities from 80 to 290 gallons per hour, at pressures up to 500 psi (#1 to 300 psi). With high-density gray iron body construction, heat-treated alloy steel gears and shafts, and heavy-duty needle bearings, B Series transfer pumps offer superior durability and high mechanical efficiency. Double lip Viton seals, are standard. B Series pumps are available in—clockwise (right hand) or counter-clockwise (left hand) rotations. All B Series transfer pumps are U.L. listed.

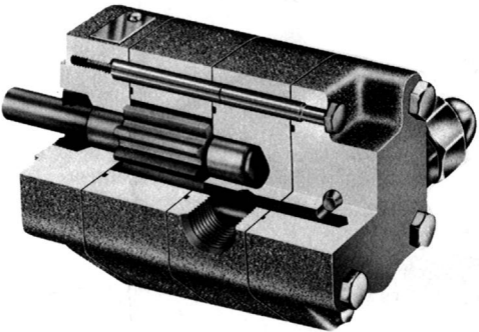

SPECIFICATIONS

B Series

Fuel Oil Transfer Pumps

Capacity:

80 to 290 gph at 1725 rpm and 100 psi (#1 to #6 fuel oil). 160 to 520 gph at 3600 rpm and 100 psi (#1 to #6 fuel oil).

Pressure:

#4 to #6 fuel oils up to 500 psi, #2 fuel to 350 psi.

Speed:

For direct or belt drive application up to 3600 rpm.

Rotation:

Clockwise rotation viewed from shaft end.

Porting:

1/2" NPTF: side inlet and side outlet ports. (18B, 37B, 47B)

3/4" NPTF: Side inlet and side outlet ports (59B)

Shaft:

Standard: .50 OD, 1.00 flat length, 1.88" extension from mounting face.

Seal:

Standard—double lip type, Viton

Mounting:

Hub, 2-1/8", with 8 standard hub spots.

Filter:

No internal filter. External filter recommended.

Maximum Inlet Vacuum:

10" Hg

U.L. Listed

SELECTION TABLE
Pump Capacity at 100 psi
with #2 Fuel Oil at 75°F.

Pump Model*	1750 rpm	
	Input hp	gph
18B	.14	80
37B	.21	155
47B	.30	220
59B	.45	290

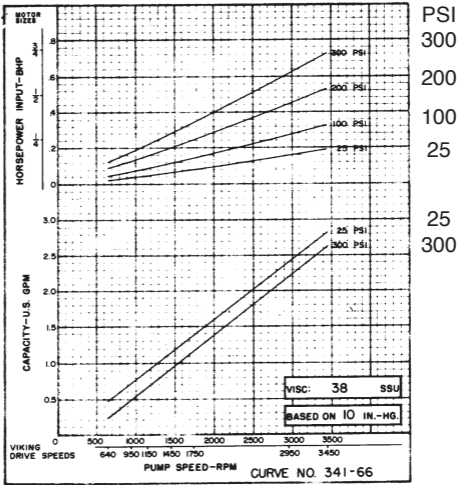

18B

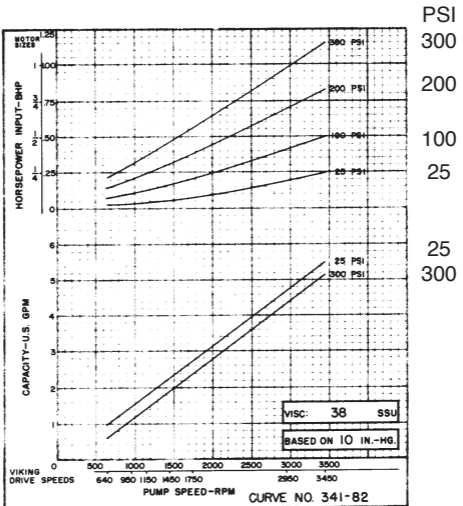

37B

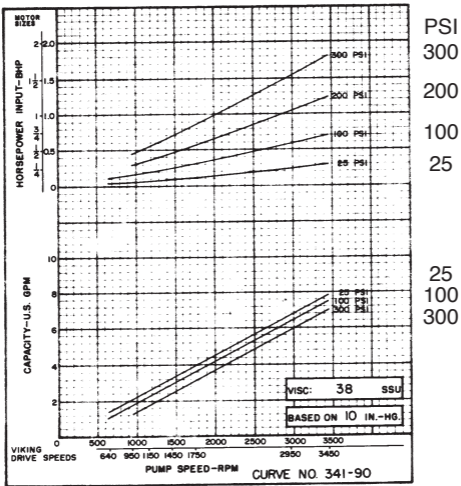

47B

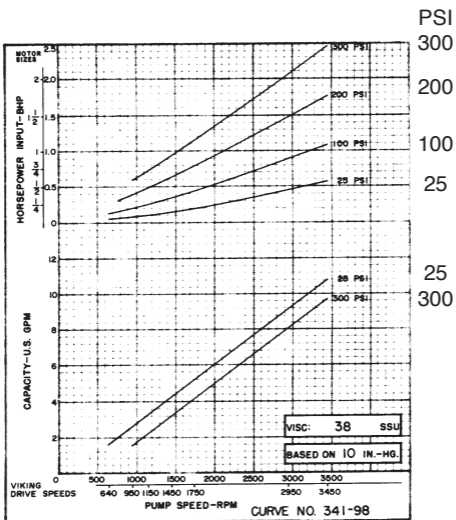

59B

INSTALLATION AND DIMENSIONAL DATA

Single-Rotation Models

Connect discharge and suction lines to NPTF ports depending on desired direction of shaft rotation. Direction of shaft rotation is always toward discharge port.

CAUTION: Do not attempt to operate pump with discharge port blocked.

Correct shaft rotation is shown by arrow stamped on back of pump. Do not attempt to operate pump in opposite direction.

Use an external regulating valve in discharge line if pressure regulation is necessary.

Installation Notes:

“Fuel unit inlet pressure should not exceed 3 psig in order to comply with National Fire Protection Association’s Bulletin 31”

To assure maximum performance, INLET VACUUM, measured at unused INLET PORT, should not exceed 10” Hg on single-stage pumps.

CODE	DIM “A”	DIM “B”
18B	3.36	2.66
37B	3.71	3.02
47B	4.05	2.13
59B	4.40	2.30

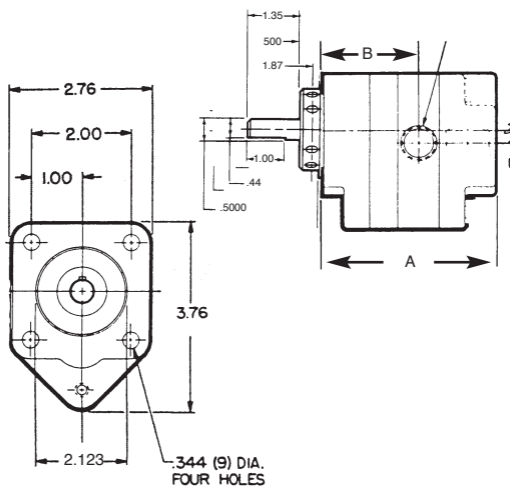

SUPPLY PUMP UNITS

Webster can offer pump sets in a variety of combinations. Webster will mount any of our low speed pump heads to any motor type. Available in simplex, duplex manual and duplex automatic configurations. See the code breakdown below.

Supply Pump and Motor Code Breakdown

Examples: SPM-50AT2R213 or SPMB-50AT59BR or SPMV-100BT086K-DA

Basic Prefix	Pump Head	Dash	Motor HP	Motor Phase	Motor Enclosure	Webster	Dash	No Letter or
Supply Pump & Motor	Series No Letter-Standard		.25=1/4 hp 500=5 hp	Voltage A=1 phase B=3 Phase X=Special Voltage 50 or 60 cy.	TEFC, OPDP E Explosion Proof	Pump Head P/N Prefix		Blank = Simplex DA - Duplex Automatic DM - Duplex Manual PLC
SPM	B-V-No Letter		.25 - 500	A, B or X	T, O or E	Pump #		Blank, DA or DM

Dimensions

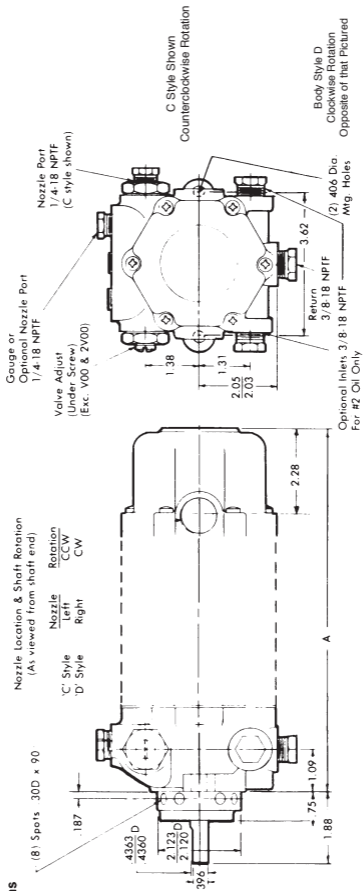

NOTE: To assure compliance with National Fire Protection Association's Bulletin 31, "Installation of Oil Burning Equipment," fuel unit inlet pressure should not exceed 3 psig.

**SPM with a "V" or "R" Series Pump Head
SINGLE SUPPLY UNIT using a 56C Frame Motor**

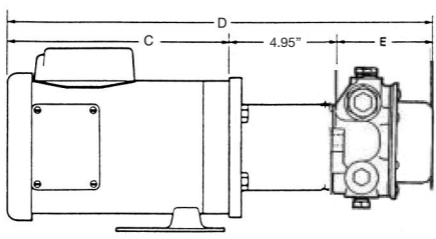

- C = Motor Length
- D = Overall Dimension
- A or E = V or R Pump Dimension

SUPPLY PUMP UNITS

GENERAL INFORMATION

Locating Units

Install transfer/supply units in a clean, dry, well-ventilated location as close to the storage tank as possible. Close installation will minimize required vacuum and will allow smallest diameter piping to be used while assuring an adequate supply of oil.

The units can be mounted in any position. Preferred position for convenient line connections is horizontal with foot mounts down.

Filter or Strainer

A reliable in-line filter or strainer is recommended between the tank and the supply pump. Filter or strainer capacity must at least equal the suction gear capacity of the pump to minimize restriction in the suction line.

Oil Safety Valves

Oil safety valves, mounted close to the burner assembly, isolate burner fuel pumps from supply line pressures. The oil safety valve relieves pressure strain on burner pump seals, and prevents tank siphoning and spilling caused by accidental line breaks. To assure compliance with National Fire Protection Association's Bulletin 31, "Installation of Oil Burning Equipment," burner fuel pump inlet pressure should not exceed 3 psig. The Webster OSV Series valves satisfy this requirement when properly installed.

An optional mesh strainer, rated for maintained system pressure, can be installed before each OSV near the burner assembly to protect the OSV from harmful scale which may occur in black iron pipe.

Tee fittings should also be inserted on the supply side of each OSV in the system. This will allow a pressure reading to be taken when setting system pressure.

Measuring Inlet Vacuum

When installation is complete, the compound gauge should be used to measure inlet vacuum.

For maximum performance, vacuum when measured at unused inlet port during operation should not exceed 15" Hg on the two-stage SPM supply pumps.

A vacuum reading greater than 15" Hg indicates inadequate oil supply, which could be a result of excessive vertical lift, undersized tubing, a plugged or undersized filter or strainer, sticking check valves, or a frozen, kinked or otherwise restricted suction line.

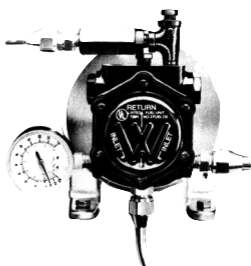

An abnormally low vacuum reading may indicate an air leak in the suction line, valves, or fittings. Generally, assume 0.75" of vacuum for every foot of vertical lift, plus frictional tubing losses, and other in-line restrictions.

When installing fuel units, to assure compliance with National Fire Protection Association's Bulletin 31, "Installation of Oil Burning Equipment," fuel unit inlet pressures should not exceed 3 psig.

SPM SERIES

FEATURES

SPM Series pump/motor units consist of a fuel pump direct coupled to a motor. an integral check valve and combination vacuum/pressure gauge. They are designed to supply fuel oil from a central storage tank to remote heating units or auxiliary tanks.

SPM pumping units were developed to supply fuel oil to one or more overhead furnaces, day tanks, or for underground central distribution. Four pump/motor sizes are available, with capacities of 15, 30, 65 and 135 gph (57, 114, 245 and 510 1/hr). 1/6 hp, 1/4 hp and 1/3 hp (124 W, 186 W and 248 W) motors are split phase available for either 115 or 230 volt operation. 1/2 hp (373 W) motors are capacitor start—induction run, totally enclosed with dual 115/230 volt windings. The units are shipped completely assembled and include a gauge and check valve. All are 60 cycle, 1750 rpm, continuous duty.

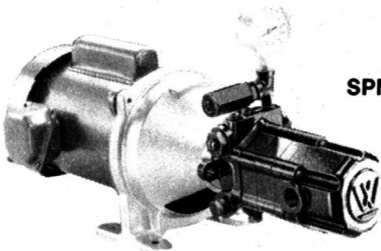

SPM-135

SPM-15, -30 & -65

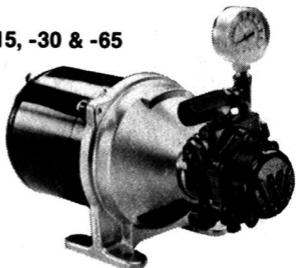

DUPLEX PUMP UNITS

SPM SERIES

FEATURES

The SPM duplex models consist of two pump/motor assemblies with a pre-piped, common discharge manifold. One pump/motor unit operates continuously, with the second providing backup service if the main pump fails. Either automatic (SPM-DA models) or manual (SPM-DM models) controls are available.

The duplex automatic series are designed specifically for buildings where a constant supply of oil must be assured ... hospitals, apartment buildings, schools and other commercial/industrial buildings

The DA Series is equipped with a pressure sensing device which detects a loss in pressure of the primary pump. If the standby pump is brought into service, an alarm sounds which indicates a malfunction in the primary pump.

The electric control circuit on the duplex automatic pump set is equipped with a lead-lag switch to permit manual alternation of pump to provide even wear on each pump.

The manually operated duplex pump sets offer the same protection as an automatic except the standby pump must be turned on manually which requires that maintenance personnel always be available.



SUPPLY UNIT SPECIFICATIONS

SPM Series Supply Units

Single and Duplex

NEMA 1
Enclosure

Capacities:

15, 30, 65, and 135 gph

Pressure:

Maximum operating pressure to 80 psi or 200' of head.

Motors:

All motors are 60 cycle, 1750 rpm, continuous duty, 48N frame, 1/6, 1/4, 1/3 hp: split phase, 115 or 230 volt operation, 1/2 hp: capacitor start/induction run, TEFC, dual 115/230 volt.

Pumps:

SPM 15, 30, and 65: uses Webster "2R" Series pump units.

SPM 135: uses the Webster "2V" Series pump unit.

Webster 2R and 2V are UL listed

Porting:

SPM 15, 30, 65:

1/4" NPTF—2 inlets, outlet port and top and bottom returns

SPM 135:

1/4" NPTF—outlet port

3/8" NPTF—return port, 2 optional inlets.

1/2" NPTF—inlet.

Seal:

All models—double lip type.

Mounting:

All models — four bolt foot mount

Filter:

Rotary self cleaning type, except in SPM 135. Use of external line filter recommended.

Valves:

Pressure regulating assembly in pump maintains set pressure.

Check valve maintains oil in feeder lines for instant starts.

Gauge:

2-1/2" dia., calibrated from 30" vacuum to 100 psi.

Controls:

Two Types for Duplex Units Only Duplex automatic with lead-lag switch and alarm. Manual with selector switch.

Maximum Inlet Vacuum:

All units—15" Hg

National Fire Protection Association compliance requires fuel inlet pressure not to exceed 3 psig.

SELECTION TABLE

Models and Design Data Table 1

Model	Type	Motor Voltage	Motor hp	Max. Head ft*	Valve Adj. Range	Watts @ 80 psi	Max Flow		Suction Cap.	Pump Model No.
							@ min. psi gph	@ 80 psi gph		
SPM-15-1	Single	115								
SPM-15-2	Single	230								
SPM-15-1-DA	Duplex-Auto.	115	1/6	200'	10 to 100 psi	65	22	15	35	2R181C-5BQ4 (35196-5)
SPM-15-2-DA	Duplex-Auto.	230								
SPM-15-1-DM	Duplex-Man	115								
SPM-15-2-DM	Duplex-Man	230								
SPM-30-1	Single	115								
SPM-30-2	Single	230								
SPM-30-1-DA	Duplex-Auto	115	1/4	200'	10 to 100 psi	95	45	30	70	2R283C-5BQ4 (35196-6)
SPM-30-2-DA	Duplex-Auto	230								
SPM-30-1-DM	Duplex-Man	115								
SPM-30-2-DM	Duplex-Man	230								
SPM-65-1	Single	115								
SPM-65-2	Single	230								

SPM-65-1-DA	Duplex-Auto.	115	1/3	200'	10 to 100 psi	175	90	65	125	2R686C-5BQ4 (35196-7)
SPM-65-2-DA	Duplex-Auto.	230								
SPM-65-1-DM	Duplex-Man	115								
SPM-65-2-DM	Duplex-Man	230								
SPM-135	Single	Dual								
SPM-135-DA	Duplex-Auto.	115/230	1/2	200'	10 to 100 psi	300	157	135	250	2V086C-5D04 (35196-8)
SPM-135-DM	Duplex-Man.	115/230								

SPM Pumps are set at 20 psi.

* Equivalent head equals vertical height from supply pump discharge to highest point in system, plus pressure drop for length of piping run, plus additional losses due to fittings.

** Pumping #2 oil (34SSUU). .85 Sp. gr.

Supply Pump Unit Cross Reference

Webster Model No.	Suntec Model No.
SPM-15-1 (1725 rpm)	—
SPM-30-1 (1725 rpm)	BH-1000M (1725 rpm)
SPM-30-1 (1725 rpm)	BB-1020M (3450 rpm)
SPM-30-1 (1725 rpm)	BH-1030H (3450 rpm)
SPM-65-1 (1725 rpm)	BH-1001M (1725 rpm)
SPM-65-1 (1725 rpm)	BH-1070M (3450 rpm)
SPM-135 (1725 rpm)	
For higher capacities, consult factory	

INSTALLATION DATA

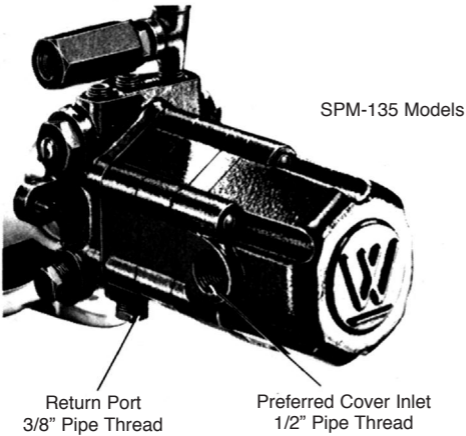
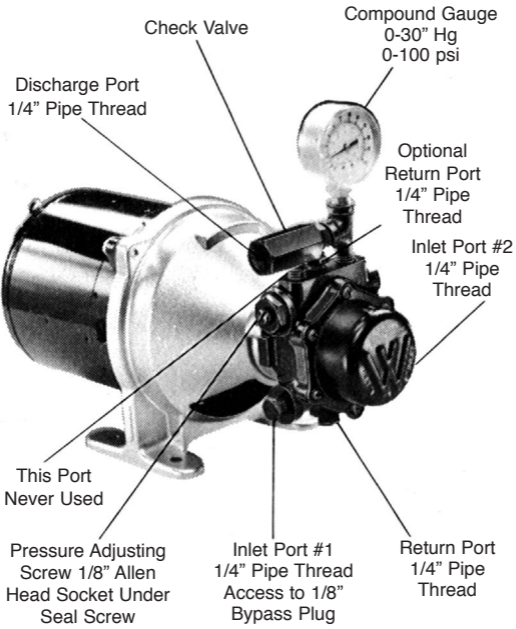

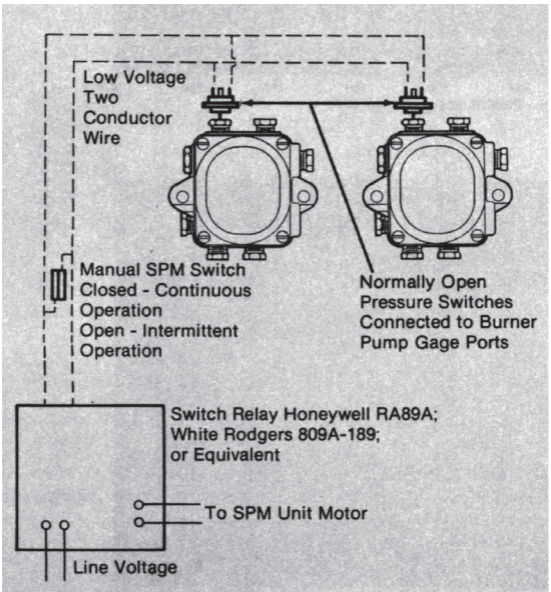
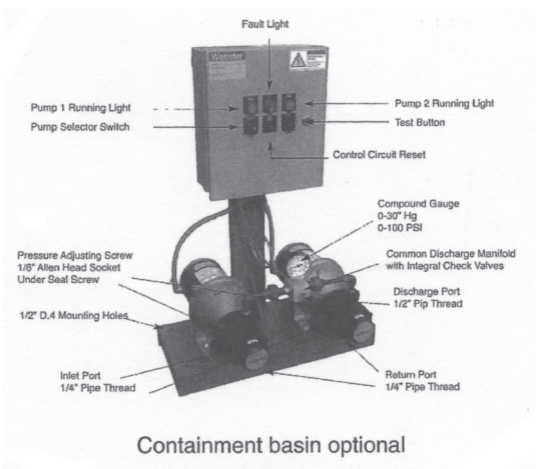

Wiring for intermittent operation

DUPLEX FUEL OIL PUMP SETS

Webster has the ability to offer pump sets in a variety of combinations. Webster will mount any of our low speed pump heads to any AC motor and panel type. Duplex Automatic and Duplex Manual configurations.

Standard Duplex Operation and Features

The SPM duplex models consist of two pump/motor assemblies with a pre-piped, common discharge manifold. One pump/motor unit operates continuously, with the second providing backup service if the main pump fails. Either automatic (SPM-DA models) or manual (SPM-DM models) controls are available.

The duplex automatic series are designed specifically for buildings where a constant supply of oil must be assured...hospitals, apartment buildings, schools and other commercial/industrial buildings.

The DA Series is equipped with a pressure sensing device which detects a loss in pressure of the primary pump. If the standby pump is brought into service, an alarm sounds which indicates a malfunction in the primary pump.

The electric control circuit on the duplex automatic pump set is equipped with a lead-lag to permit alteration of pump to provide even wear on each pump.

The manually operated duplex pump sets offer the same protection as an automatic except the standby pump must be turned on manually which requires that maintenance personnel always be available.

Standard SPM Duplex Pump Sets

(Models SPM-15, SPM-30, SPM-65 and SPM-135)

Selection Table
Models and Design Data Table

Standard SPM Series Duplex Automatic Supply Pumps

Model	Type	Motor Voltage	Phase	Motor HP	Max Head	Valve Adjustment Range	Max Flow @ 10 psi	Max Flow @ 100 psi
SPM-15-1-DA	Duplex Auto	115	Single	1/5	200'	10 to 100 psi	22	15
SPM-15-2-DA	Duplex Auto	230	Single	1/3	200'	10 to 100 psi	22	15
SPM-33BT2R181-DA	Duplex Auto	230/460	Three	1/3	200'	10 to 100 psi	22	15
SPM-30-1-DA	Duplex Auto	115	Single	1/4	200'	10 to 100 psi	45	30
SPM-30-2-DA	Duplex Auto	230	Single	1/3	200'	10 to 100 psi	45	30
SPM-33BT2R283-DA	Duplex Auto	230/460	Three	1/3	200'	10 to 100 psi	45	30
SPM-65-1-DA	Duplex Auto	115	Single	1/3	200'	10 to 100 psi	90	65
SPM-65-2-DA	Duplex Auto	230	Single	1/3	200'	10 to 100 psi	90	65
SPM-33BT2R686-DA	Duplex Auto	230/460	Three	1/3	200'	10 to 100 psi	90	65
SPM-135-DA	Duplex Auto	115/230	Single	1/2	200'	10 to 100 psi	157	135
SPM-50BT2V086-DA	Duplex Auto	230/460	Three	1/2	200'	10 to 100 psi	157	135

The Above pumps are set at 20 psi

The Standard Duplex Panel is also available for our SPMB and SPMV pump sets.

Our Standard Duplex Automatic Fuel Oil Transfer Pumps are available with the following.

- Flow rates from 15 GPH up to 135 GPH
- Discharge pressures from 10-100 psig
- 1725 rpm Direct Drive Motors
- Two Pump and Motor assemblies
- Duplex Automatic Panel with Automatic Switch Over
- One Hand-Off-Auto switch
- One Lead Lag Pump Switch
- Two "Pump On" indicator lights
- Duplex panel Test Button
- Alarm with Indicator Light
- One Reset Circuit Breaker
- Two Magnetic Motor Starters with Overload Protection
- One Compound Gauge on discharge block
- One Discharge connection

Dimensions

Model	A	B	C	D
SPM-15	6.88	15.50	—	—
SPM-30	7.44	18.13	—	—
SPM-65	8.98	19.50	—	—
SPM-135	10.94	21.70	7.75	21.70

*SPM-135 3 PHASE

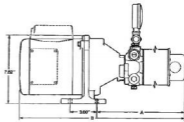
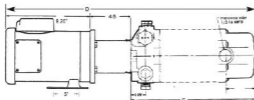

Dimensions Duplex Automatic

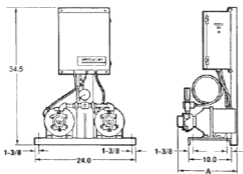

Model	A	Pipe Tap
SPM-15-DA	14.94	1/4
SPM-30-DA	16.53	1/4
SPM-65-DA	16.00	1/4
SPM-135-DA	21.37	3/8

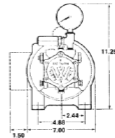

Dimensions Duplex Manual

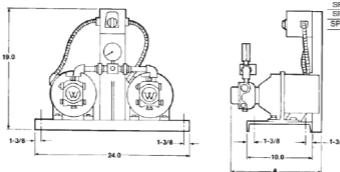

Model	A	Pipe Tap
SPM-15-CM	14.94	1/4
SPM-30-CM	16.53	1/4
SPM-65-CM	16.00	1/4
SPM-135-CM	21.37	3/8

INSTALLATION DATA

SPM Single and Duplex Manual Models

SPM Single and Duplex Manual units are capable of supplying fuel oil to heating units or tanks located up to 200 feet above the supply pumps. They are designed for use in maintained pressure or open loop systems. Pump pressures can be set at a range from 10 psi to 100 psi. See Correct Supply Line Size charts, for maximum discharge head.

Tank to Pump Connections

Connect suction line from the tank to preferred supply pump inlet port. Connect return line from pump return port to tank. Internal 1/8" bypass plug (factory installed) must be in position for recommended two-pipe operation. *Be certain all plugs and connections are secure and leak tight.*

The correct suction line size can be determined by referring to the charts. Generally, the return line should be sized the same as the suction line. Check valves in the suction lines between the tank and SPM units assure that pumps are full of oil, ready for service. Check valves must be oil tight. Low pressure drop swing type are recommended to minimize friction loss.

For SPM Duplex Manual models, preferred installation calls for a separate suction line from tank to pump for each pump/motor unit. If system failure occurs because of a gross leak in the suction line of the primary unit, the second unit can still provide backup service. Check valves can be installed in return lines to allow removal of inactive pump for servicing, while primary pump continues to run.

These typical installation diagrams, illustrating a maintained pressure supply system or optional open loop system, for continuous pump operation, are shown for reference only. Compliance to all applicable codes where installed is the sole responsibility of the installer.

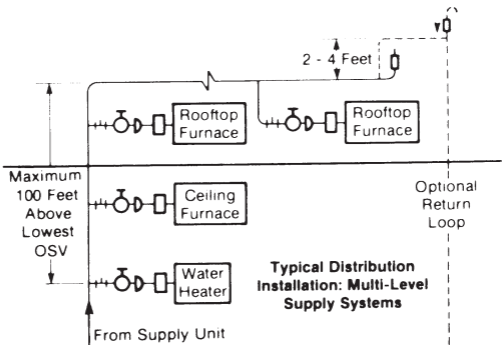

Typical Installations

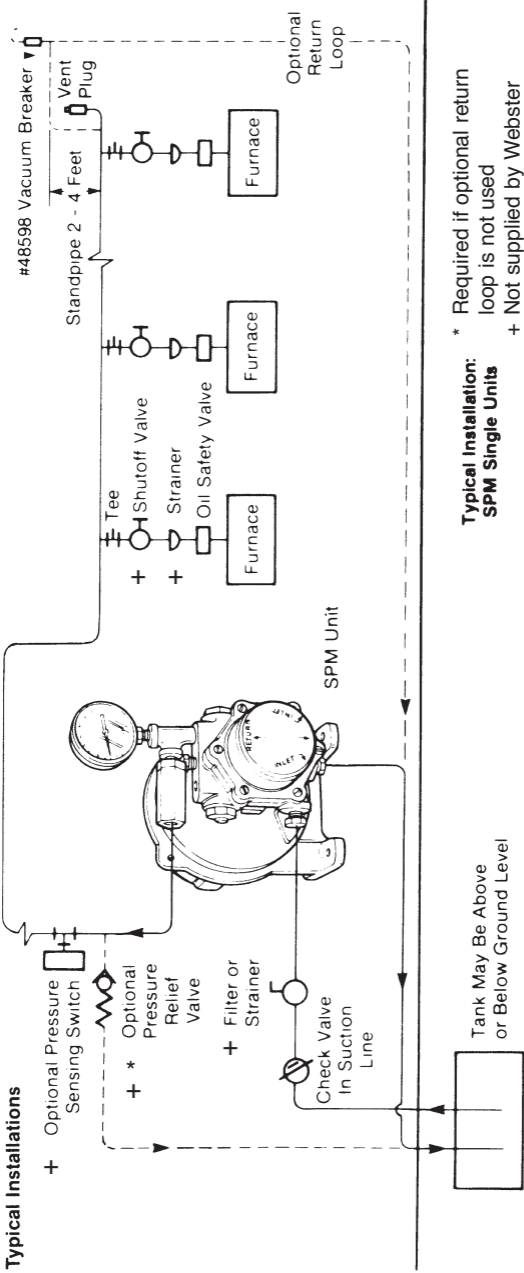

+ Optional Pressure Sensing Switch

+ * Optional Pressure Relief Valve

+ Filter or Strainer

Check Valve In Suction Line

SPM Unit

Tank May Be Above or Below Ground Level

Typical Installation:
SPM Single Units
 * Required if optional return loop is not used
 + Not supplied by Webster

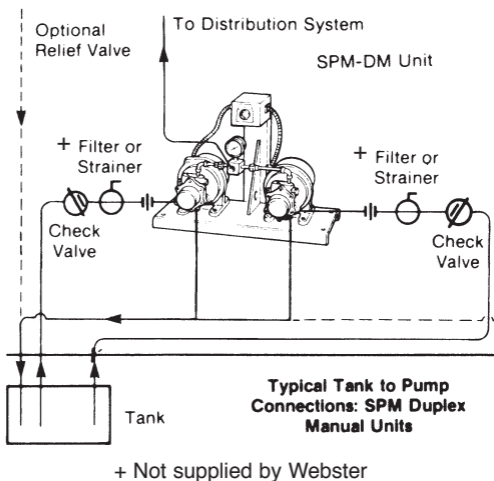

SPM Duplex Automatic Models

SPM Duplex Automatic units consist of two SPM Series pump/motor assemblies and an electrical control panel. They are designed for use in maintained pressure supply systems *only*. If system pressure falls below a pre-set level, the control automatically switches from the primary pump/motor unit to the secondary unit. If the backup pump/motor unit also fails to reach or maintain preset system pressure, the control also shuts off the backup unit.

A pump selector switch allows the two pump/motor units to be manually alternated for even wear on each pump. Pump pressures can be set at a range from 10 psi to 100 psi. See Correct Supply Line charts, for maximum discharge head.

Tank to Pump Connections

Units should be set for two-pipe operation. Preferred installation calls for a separate suction line from tank to pump for each pump/motor unit. If system failure occurs because of a gross leak in the suction line of the primary unit, the second unit can still provide backup service.

The correct suction line size can be determined by referring to the charts. Generally, the return line should be sized the same as the suction line. Low pressure drop, swing type check valves can be installed in the suction lines, assuring that pumps are full of oil, ready for service. Check valves in return lines allow removal of inactive pump for servicing. Use of shutoff valves in return lines is not recommended. *Be certain all plugs and connections are secure and leak-tight.*

SPM LINE SIZING

Correct sizing of the suction and discharge lines between the storage tank and supply unit is vital. The use of tubing or pipe which is too small can result in restricted oil supply. The following charts are listed to help in line sizing for supply unit installation.

The charts can assist in determining the suggested minimum suction and discharge line sizes for Standard Schedule 40 iron or steel pipe (IPS) and for Type K copper tubing, which is recommended for underground service.*

To use the line sizing charts, first a supply unit must be sized to meet the specific application. Once this has been accomplished, the unit model number (ex. SPM-30) should be used as a guide in referring to the correct suction and/or discharge sizing charts.

NOTE: The use of pipe or tubing which is too small can cause increased frictional losses. The result could be an inadequate system discharge pressure. Check local and state codes pertaining to oil heating systems for any requirements which may affect the installation and/or operation of the system.

The following charts apply to all SPM Single, SPM Duplex Manual and SPM Duplex Automatic models. These charts are not intended to be used in sizing pipe for any other supply or transfer pump/motor units.

*Charts represent maximum horizontal run vs. vertical lift or vertical head for Standard Schedule 40 iron or steel pipe (IPS) and for Type K copper tubing, recommended for underground service. The actual OD and wall thickness are indicated for each tube size. (NOTE: The nominal size of Type K tubing is 1/8" smaller than actual OD.)

RECOMMENDED SUCTION LINE SIZE SPM-15

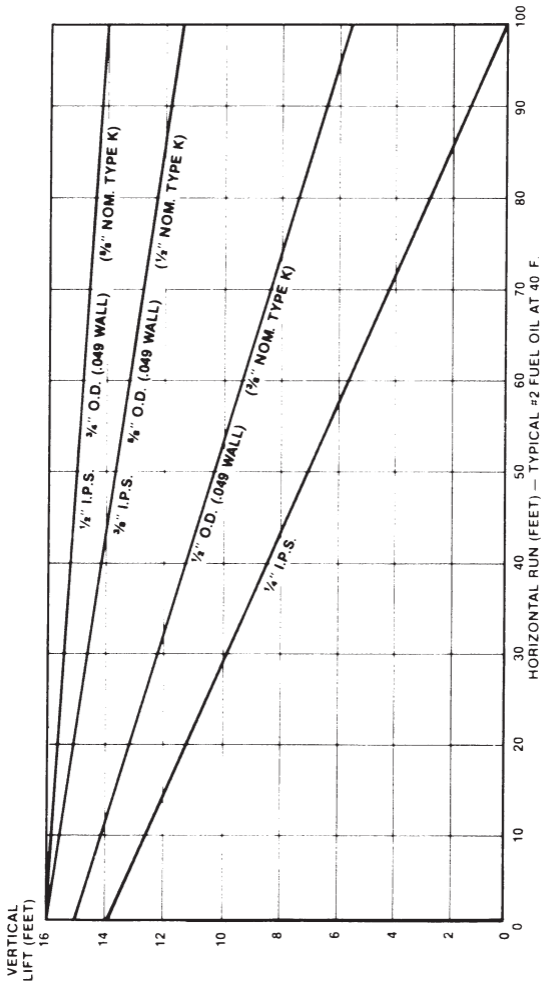

RECOMMENDED SUCTION LINE SPM-30

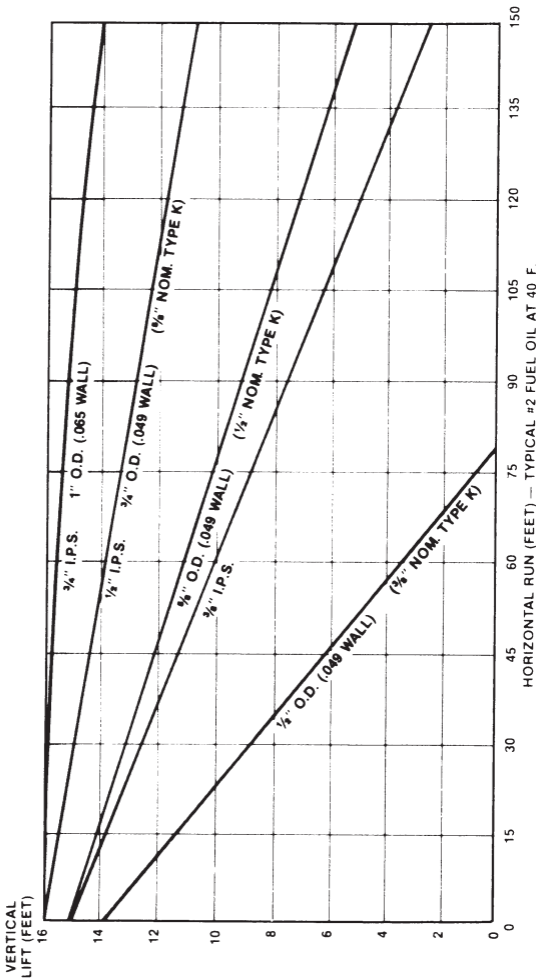

Suction Charts represent maximum horizontal run vs. vertical lift for Standard Schedule 40 iron or steel pipe (IPS) and for Type K copper tubing, recommended for underground service. The actual OD and wall thickness are indicated for each tube size. (NOTE: The nominal size of Type K tubing is 1/8" smaller than actual OD.)

RECOMMENDED SUCTION LINE SIZE SPM-65

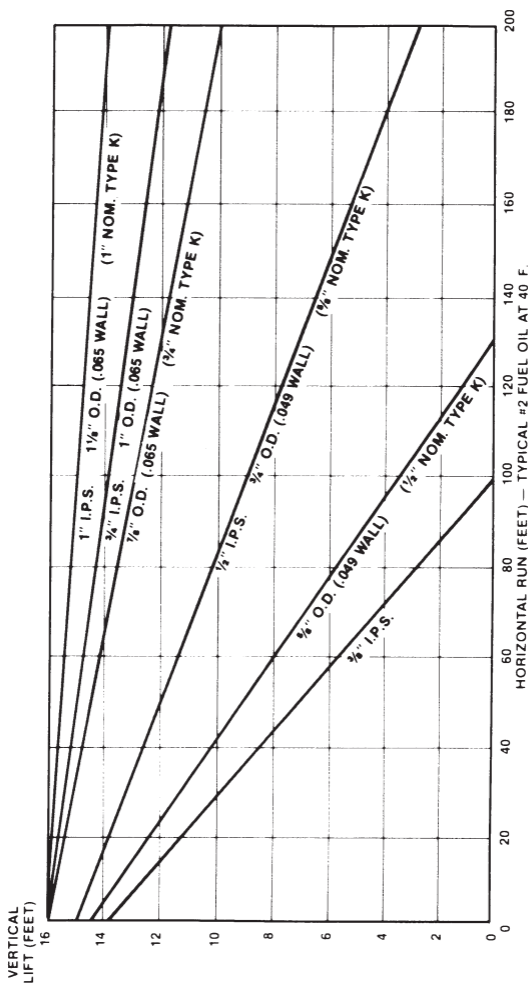

RECOMMENDED SUCTION LINE SPM-135

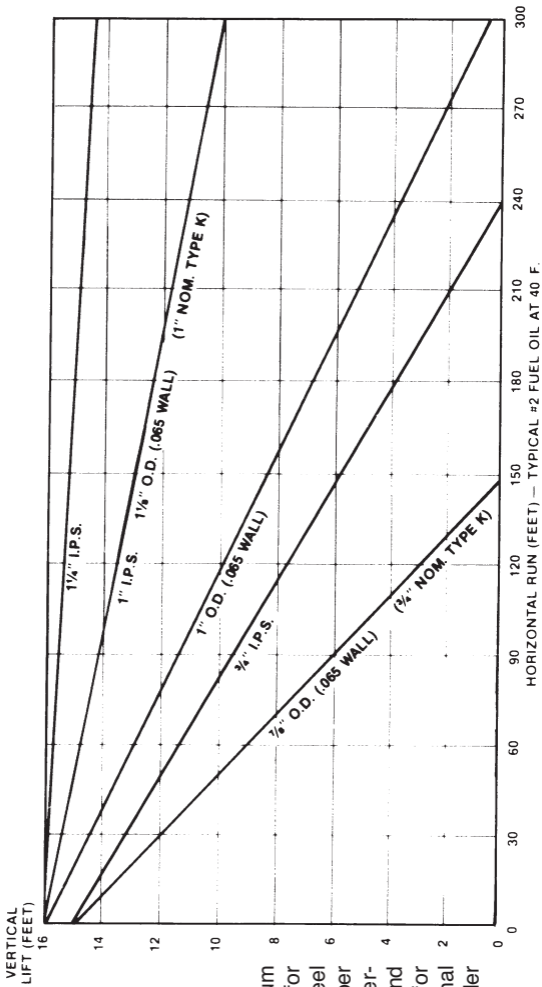

Suction Charts represent maximum horizontal run vs. vertical lift for Standard Schedule 40 iron or steel pipe (IPS) and for Type K copper tubing, recommended for underground service. The actual OD and wall thickness are indicated for each tube size. (NOTE: The nominal size of Type K tubing is 1/8" smaller than actual OD.)

RECOMMENDED DISCHARGE LINE SIZE SPM-15

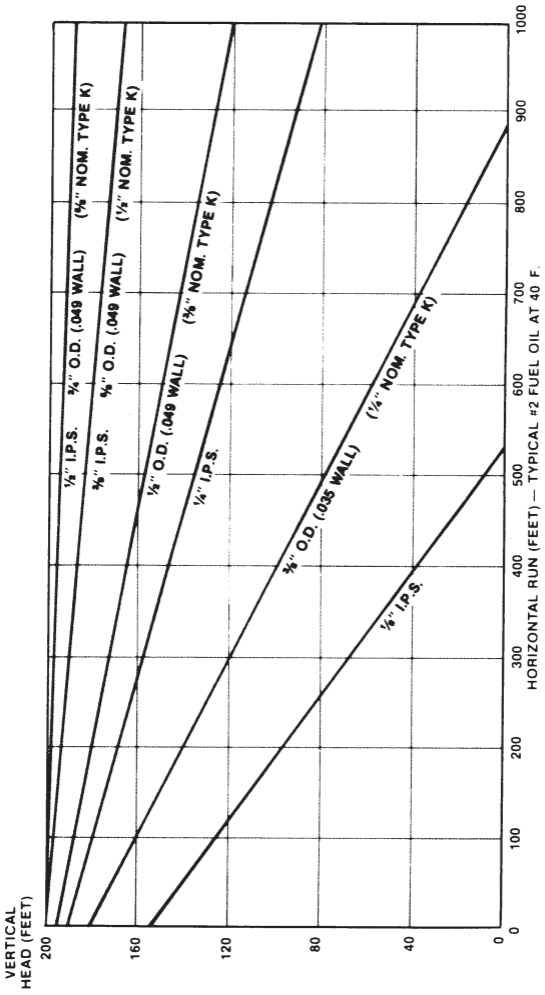

RECOMMENDED DISCHARGE LINE SPM-30

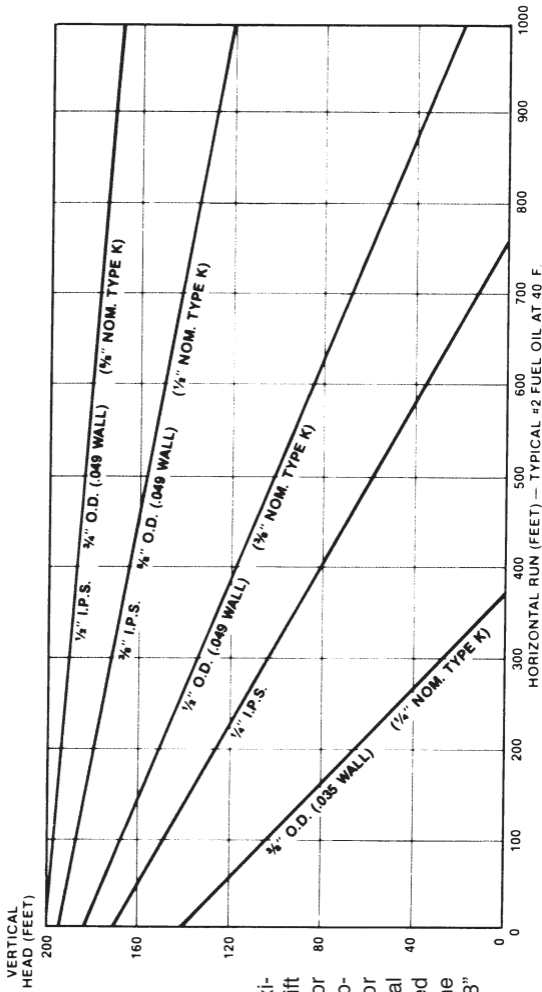

Discharge Charts represent maximum horizontal run vs. vertical lift for Standard Schedule 40 iron or steel pipe (IPS) and for Type K copper tubing, recommended for underground service. The actual OD and wall thickness are indicated for each tube size. (NOTE: The nominal size of Type K tubing is 1/8" smaller than actual OD.)

RECOMMENDED DISCHARGE LINE SIZE SPM-65

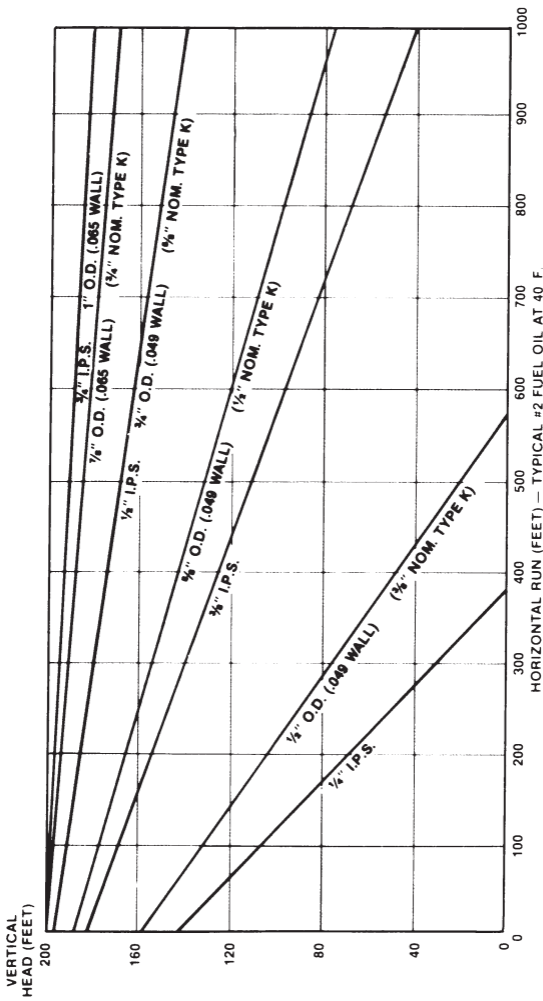

RECOMMENDED DISCHARGE LINE SPM-135

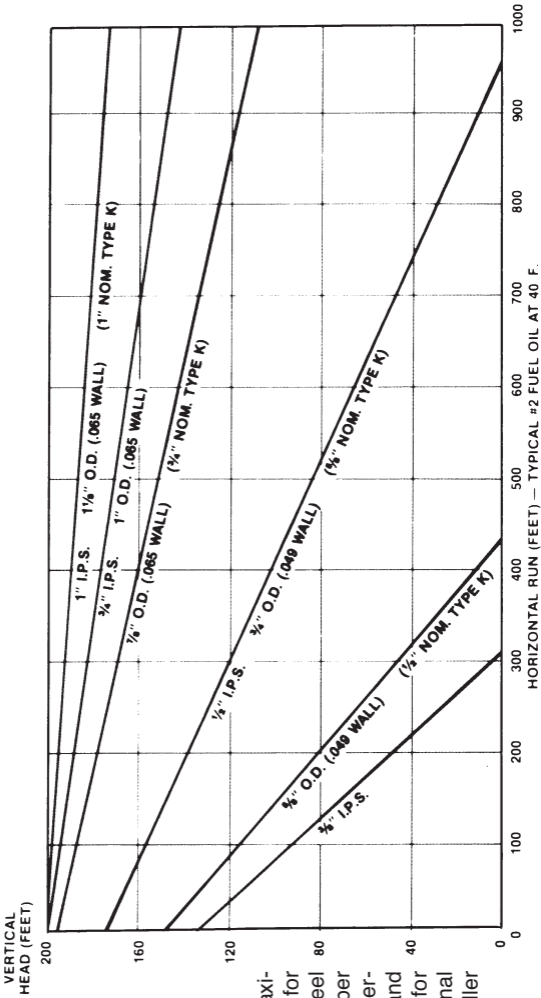

Discharge Charts represent maximum horizontal run vs. vertical lift for Standard Schedule 40 iron or steel pipe (IPS) and for Type K copper tubing, recommended for underground service. The actual OD and wall thickness are indicated for each tube size. (NOTE: The nominal size of Type K tubing is 1/8" smaller than actual OD.)

RECOMMENDED DISCHARGE LINE SIZE SPM-15-DA

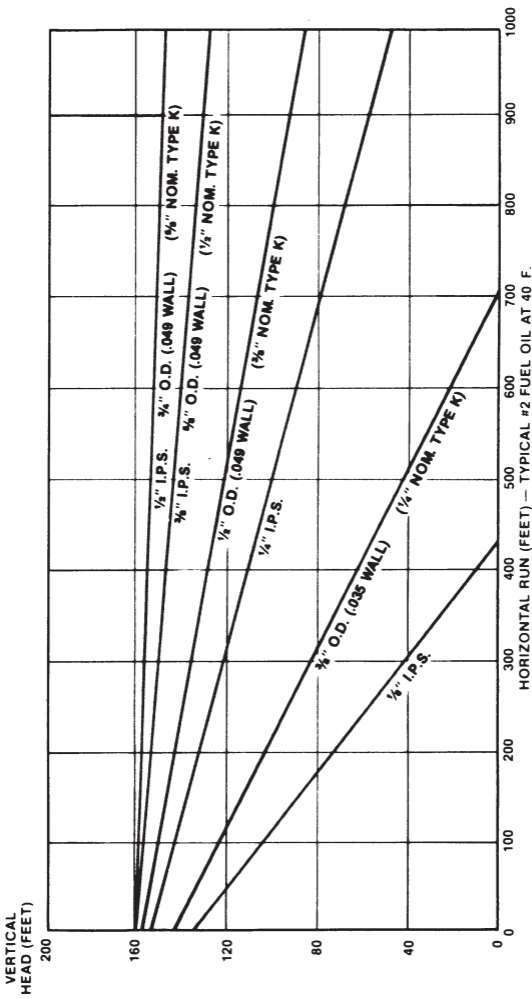

RECOMMENDED DISCHARGE LINE SPM-30-DA

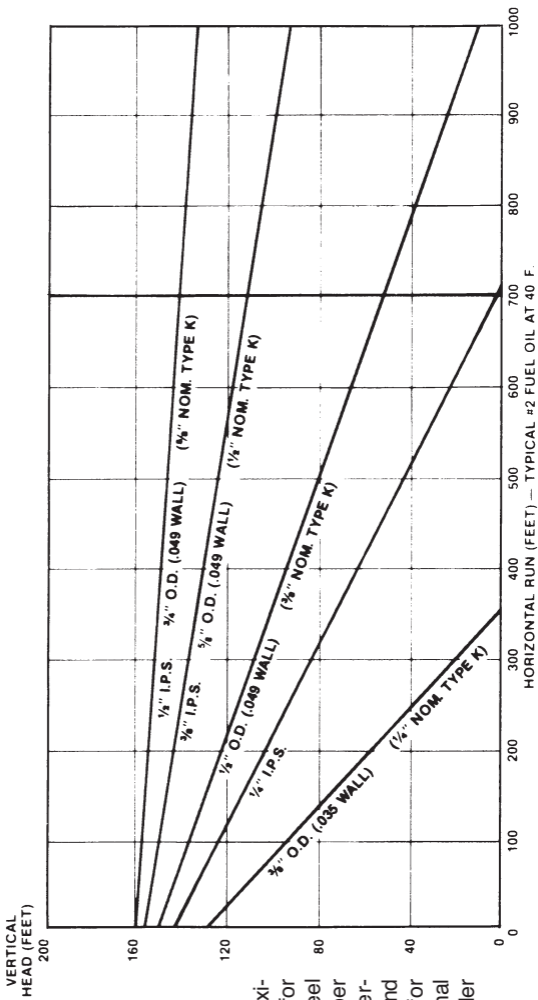

Discharge Charts represent maximum horizontal run vs. vertical lift for Standard Schedule 40 iron or steel pipe (IPS) and for Type K copper tubing, recommended for underground service. The actual OD and wall thickness are indicated for each tube size. (NOTE: The nominal size of Type K tubing is 1/8" smaller than actual OD.)

**RECOMMENDED
DISCHARGE LINE
SIZE
SPM-65-DA**

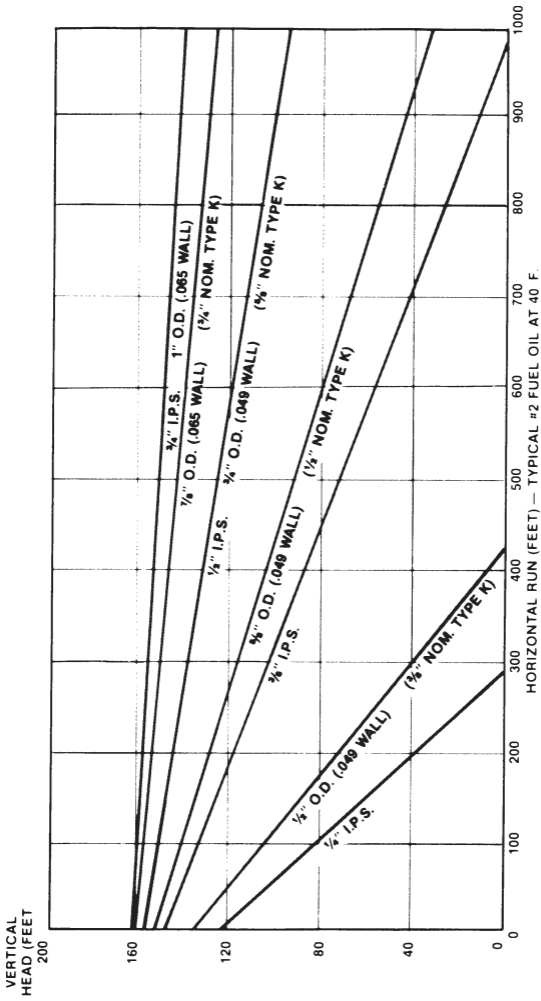

RECOMMENDED DISCHARGE LINE SPM-135-DA

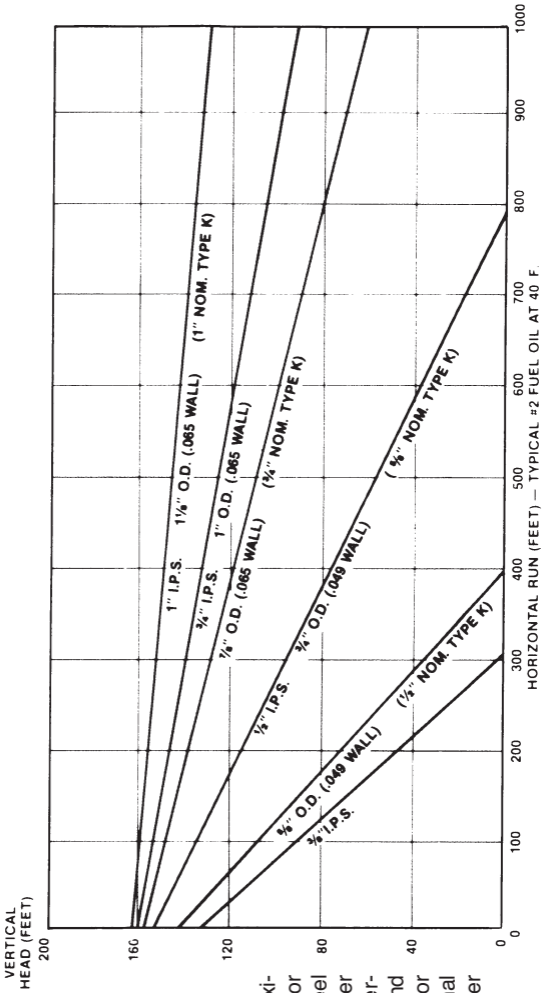

Discharge Charts represent maximum horizontal run vs. vertical lift for Standard Schedule 40 iron or steel pipe (IPS) and for Type K copper tubing, recommended for underground service. The actual OD and wall thickness are indicated for each tube size. (NOTE: The nominal size of Type K tubing is 1/8" smaller than actual OD.)

SPM Duplex Automatic Controls

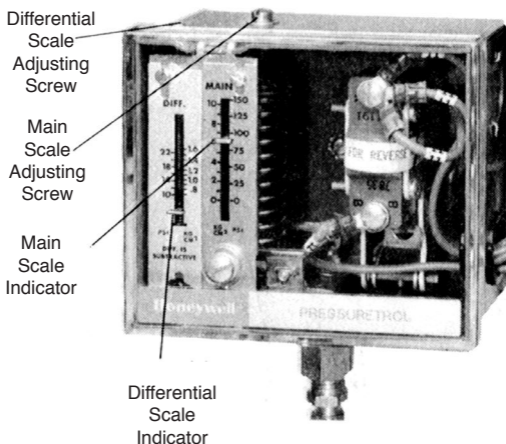

The adjusting screws on the Pressuretrol, located in the factory wired control panel, should be set carefully according to instructions, below.

Setting Pump Pressure

1. Set the differential scale indicator on the pressuretrol at approximately 5 (half-way between 10 and bottom of scale). This permanently sets the differential scale. Set main scale indicator at 0, so supply pump can run continuously during purging of supply line.
2. Purge lines. Run both supply pumps to assure both are oil filled. For priming purposes, OSV valves can be manually operated by inserting a stiff wire (paper clip) through the cover hole, and depressing the diaphragm plate.
3. Pressure adjustment, *pump one*: Install compound gauge in tee fitting in supply line of highest or most remote burner. After starting *pump one*, start all burners. With all burners operating at maximum firing rate, adjust *pump one* so gauge at remote burners, reads 20 psi.
4. Pressuretrol adjustment: With all burners firing, switch to *pump two* and adjust *pump two* so gauge at last burner reads slight positive pressure (2-5 psi). Gradually increase the pressuretrol main scale setting until *pump two* stops, *pump one* starts, and alarm buzzer sounds. Allow *pump one* to run and build pressure. With *pump one* running and *pump two* off, turn *pump two* pressure adjusting screw about one-quarter turn clockwise.
5. Pressure adjustment, *pump two*: Move selector switch to *off* momentarily, then back to *pump two*. Alarm will shut off and *pump two* will start. Adjust *pump two* pressure setting so it is the same as *pump one* (set in step three). Switch back and forth between both pumps

to confirm pressure settings are identical. Shut off all burners. Pressure at any oil safety valve in system must not exceed maximum operating pressure of 60 psi, when supply pump is running and all burners are off.

ELECTRICAL CONNECTIONS

The electrical connections between the pump/motor assemblies and control panel are made at the factory. Connect electric service to the terminal strip in the control panel using conduit and wire sizes as required by local codes.

Control circuits operate on 115 volts. Always connect white neutral wire to Terminal 2. Never connect 230 volts between Terminal L1 and Terminal 2. Green ground wire from power source should be connected to one of the panel mounting screws.

Important: SPM-135-DA motors are dual voltage and are prewired for 230 volts at factory. To operate on 115 volts, consult motor manufacturer's instructions accompanying unit for proper wiring.

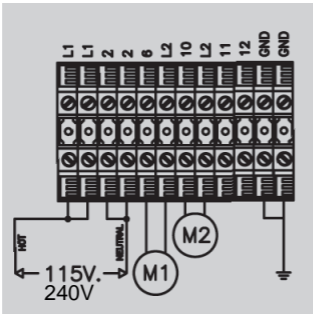

SPMV SERIES



High Capacity AC Motor/Pump Units 430-1730 gph

Designed for high capacity applications where 430-1730 gph are required. Quiet running, gear type pumps are available in four sizes and incorporate hardened integral shafts, journals and gears, special anti friction bearings, Buna N seals, and cast iron gear plates. Standard motors ranging from 1/2 hp to 7.5 hp (373 W to 5.6 kw) are 1725 rpm NEMA "C" face, 115 volt single-phase or 230 volt three-phase, 60 cycle type with TEFC enclosures through 2 hp (1490 W) and OPDP enclosures over 2 hp (1490 W).

Webster AC motor/pump high capacity fuel oil supply units are designed to be used with fuel oils including JP4 whose viscosities do not exceed 6,000 S.U.S. and with a suction less than 10" of mercury or an inlet pressure not to exceed 35 psi continuously (capable of intermittent duty at 10,000 S.U.S., 20" of mercury and 50 psi inlet). The unit is designed to operate in -20°F to +200°F conditions. The motor is precision aligned and coupled to the pump with a machined adapter and flexible couplings.

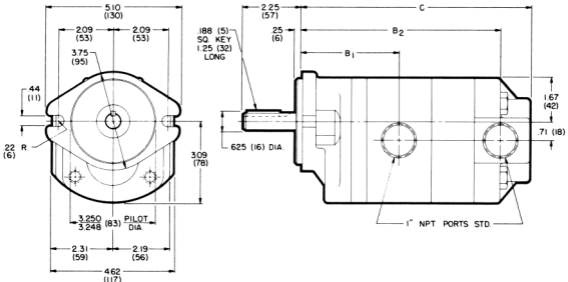

SPMV DUPLEX

Pump/Motor Units

Available in flow rates from 430 GPH through 1730 GPH. Systems can be designed for single phase 115/208/230V, 60 or 50CY, or three phase 208/230/460V, 60 or 50CY, applications. The SPM duplex models consist of two pump and motor assemblies with a pre-piped common discharge manifold. One pump operates continuously, with the second providing backup services if the main pump fails. Either automatic (SPM-DA models) or manual (SPM-DM models) controls are available. The duplex automatic series are designed specifically for buildings where a constant supply of oil must be assured...hospitals, apartment buildings, schools and other commercial or industrial buildings. The duplex pump set has a second pump for standby or auxiliary service. Furnished with automatic or manual standby controls, the duplex automatic is equipped with a pressure sensing device which detects loss of pressure of primary pump. If standby pump is brought into service, an alarm sounds which indicates malfunction in primary pump. The electric control circuit on the duplex automatic pump set is equipped with a lead-lag switch to permit manual alternation of pump to provide even pump wear. The manually operated duplex pump sets offer the same protection as the automatic except the standby pump must be turned on manually which requires that maintenance personnel always be available.



SPECIFICATIONS

SPMV SERIES

AC High Capacity Fuel Oil Supply Units

Capacity:

430 to 1730 gph with fluid viscosity to 10,000 SSU.

Pressure:

Inlet pressure should not to exceed 3 psi.

Outlet pressure up to 500 psi.

Fluid Temperature Limits:

-20° F to +200° F.

Motors:

Standard: 60 cycle, 1750 rpm, NEMA 56C frame.

1/2 through 7 1/2 hp available.

To be specified when ordering: Single-phase 115/230 VAC, or three-phase 230/460 VAC. ODP or TEFC.

Porting:

1" NPT (086K-194K)

1 1/2 X 1 1/4 NPT (237K-388K)

Mounting:

Integral mounting foot.

Maximum Inlet Vacuum: 15" Hg

Continuous operation: 10" Hg

Use of external filter recommended.

In applying these supply units, the pressures indicated are at the pump outlet. You must also consider line losses.

All pumps relying on atmospheric pressure to push the fuel oil into them are subject to cavitation. As fuel viscosity (thickness) increases, the tendency for cavitation becomes greater. Therefore, it is best to mount the pump at the base of the tank and to use the largest diameter, shortest length, and straightest inlet possible. A large diameter inlet pipe or hose necked down at the pump is preferable to a longer length of smaller diameter pipe because the fuel tends to adhere to the inside of the pipe.

When initially starting a unit, it is desirable and sometimes necessary to have a vent valve or plug on the pressure side of the pump to facilitate its priming.

SPMV PUMP CODE ANALYSIS SELECTION TABLES

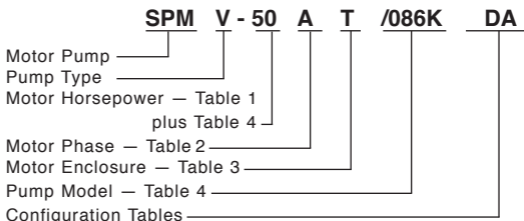

Table 1. Motor Horsepower (1725 rpm Standard)

No.	Description
50	.50 hp
75	.75 hp
100	1.0 hp
150	1.5 hp
200	2.0 hp
300	3.0 hp
500	5.0 hp
750	7.5 hp

Table 2. Motor Phase

Code	Description
A	Single-phase, 60 cycle, 115/230 VAC
B	Three-phase, 60 cycle, 230/460 VAC
X	Consult factory for other types

Table 3. Motor Enclosure

Code	Description
T	TEFC std. thru 2 hp
O	OPDP std. over 2 hp
E	Explosion Proof

Table 4. Pump Model

Maximum gph Nominal	Pump Model	Under Pressure, Read Horsepower Required at 1750 rpm			
		25 psi	100 psi	200 psi	300 psi
439	086K	.50	.75	1.00	1.50
900	194K	1.00	1.75	2.50	3.00
1114	237K	1.00	2.00	3.00	4.00
1730	388K	2.00	3.50	4.50	6.00

HP ratings shown are for No. 2 fuel oil. Consult factory for hp ratings for heavier weight oils. For lower flow rates consult Bulletin 131-49161. For higher pressures and/or flow rates, consult factory.

SPMV Duplex Ordering Code

When ordering SPMV Duplex models add suffix:

“DM,” for manual control models, or “DA,” for automatic control models.

Example: SPMV-50AT/086K-DA

5	Code	Duplex Units
	DM	Duplex with manual controls
	DA	Duplex with automatic controls

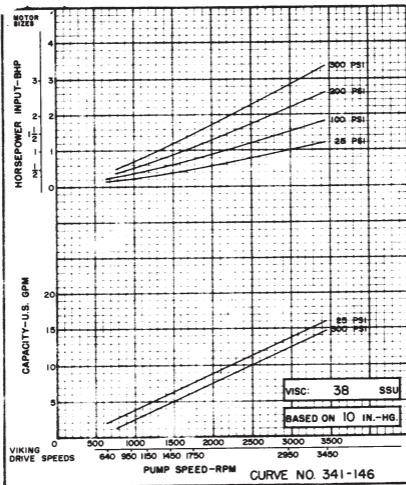

PSI
300
200
100
25

25
300

086K

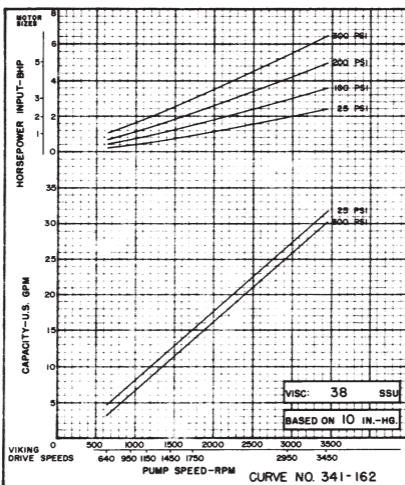

PSI
300
200
100
25

25
300

194K

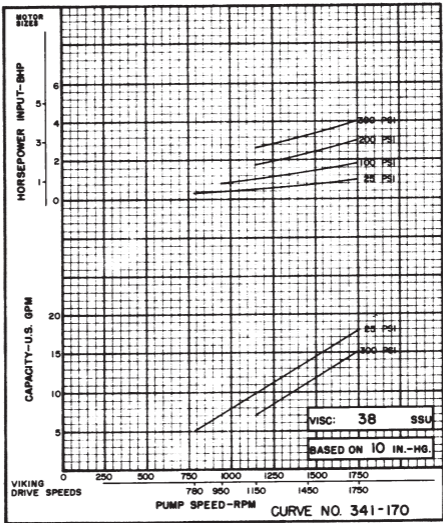

PSI
300
200
100
25

25
300

237K

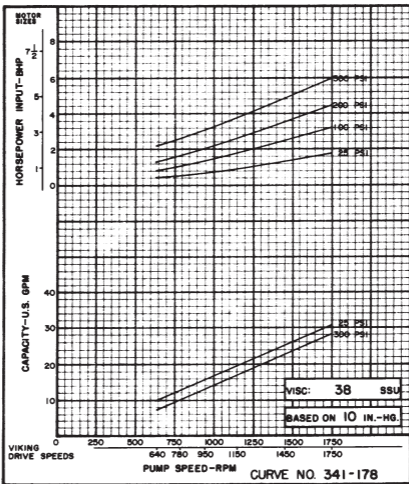

PSI
300
200
100
25

25
300

388K

SPMV Series Single and Duplex Supply Units

DIMENSIONS

<i>Motor</i>						
<i>HP</i>	<i>NEMA Frame Size</i>	<i>Type (Standard)</i>	<i>A</i>	<i>B</i>	<i>C</i>	<i>D</i>
.75	56C	TEFC	2.5	9.00	8.25	9.20
1.00	56C	TEFC	2.5	9.00	8.25	10.20
1.50	56C	TEFC	2.5	9.00	8.25	11.20
2.00	56C	TEFC	2.5	9.00	8.25	11.20
3.00	182TC	OPDP	7.30	9.63	11.05	11.00
5.00	184TC	OPDP	7.30	9.63	11.05	12.40
7.50	213TC	OPDP	8.00	11.63	13.00	13.90

<i>Pump Model</i>	<i>E</i>	<i>F</i>		<i>G</i>
		<i>Minimum</i>	<i>Maximum</i>	
086K	4.90	19.05 (.50HP)	20.85 (3.00HP)	3.65
194K	5.65	19.80 (.75HP)	23.10 (5.00HP)	4.50
237K	8.80	22.95 (.75HP)	27.85 (7.50HP)	4.25
388K	9.80	23.95 (.75HP) *	28.65 (7.50HP)	CALL

* Add 4" for Explosion Proof

SPMV SINGLE SUPPLY UNIT

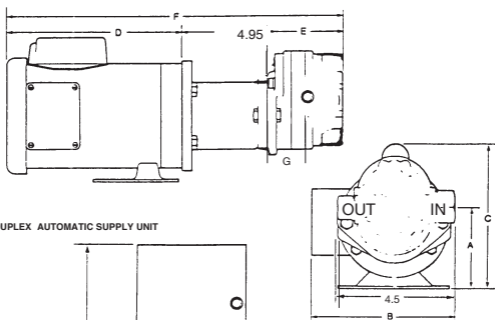

SPMV DUPLEX AUTOMATIC SUPPLY UNIT

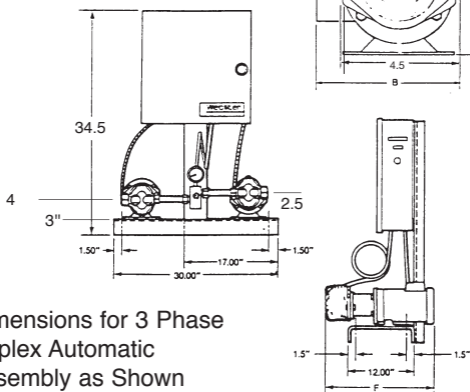

Dimensions for 3 Phase
Duplex Automatic
Assembly as Shown

Webster PLC Based Duplex Automatic Pump Sets (Models SPM, SPMB and SPMV Series)

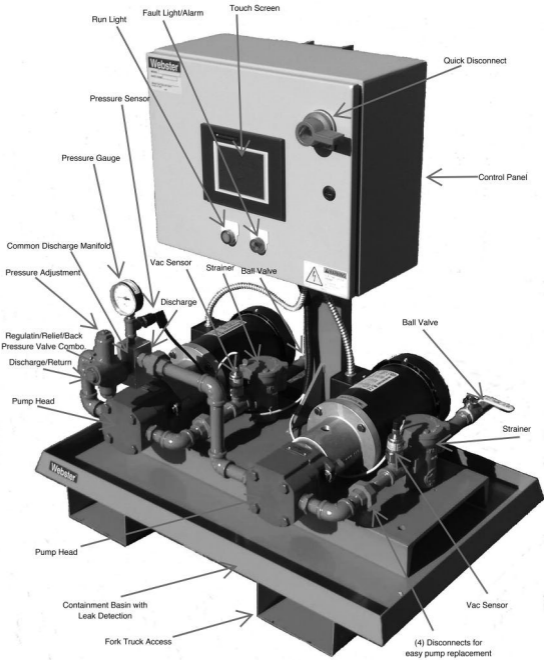

The above SPM pump set is sitting on a 36" x 24" containment basin. Dimensions may vary depending on model.

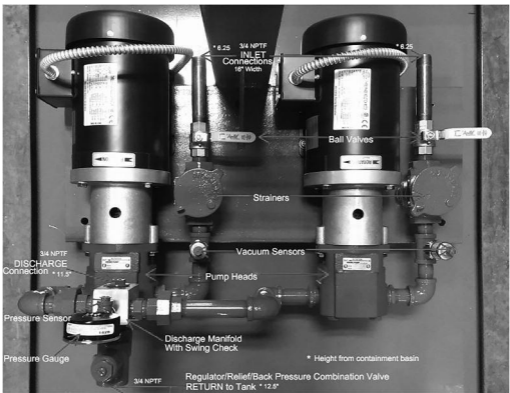

The Duplex Automatic Pump and Motor PLC Based Oil Management Control Panel options below are pre-programmed into the PLC.

- Microprocessor Base Programmable Logic Controller
- Remote Monitoring Capabilities via Ethernet and or Wireless Communication. Internet connection is needed to interface with the PLC panel in order to provide real time remote monitoring.
- Audio and Visual Alarm
- Duplex Automatic Panel with Automatic Switch Over
- High/Low Level and Leak Detection Interface with Alarm and Shut Down
- Automatic Alternation will allow for equal run time between pump sets every 14 days
- Pressure Transducer to detect pump failure and to allow back-up pump to energize
- 6" LED Touch Display Panel
- Vacuum and Pressure Monitoring
- Motor Starters with MCP's (Motor circuit protector)
- Quick Disconnect
- ETM Time Elapsed Recorders for Each Pump Set for Later Verification
- Event Summary
- NEMA 4/12 Enclosure
- Control System is equipped to monitor and control
 1. Hand-Off-Automatic Control
 2. Lead Pump Selection - Auto/Manual
 3. Pump Status - Off/Run/Standby
 4. Pressure and Vacuum Status-Normal/High/Low
 5. Main Tank/Day Tank Status-Normal/High/Low/Leak
- Controllers are field expandable using plug-in input modules to monitor up to 4 storage tanks and 12 discriminating leak sensors.
- Motor Failure Alarm
- Light to indicate normal power on, run, and off conditions
- Remote HMI Access for real time remote monitoring and control (C'more HMI APP Download Required)
- Advanced features of Touch Panel: Remote Access and Control feature. Send email with embedded PLC data, Send logged data to an external PC, retrieve logged panel data remotely via the internet, and clear old logged data on a routing frequency. Unit can communicate with different brands of PLC's at the same time.

Below is the front panel touch screen display.

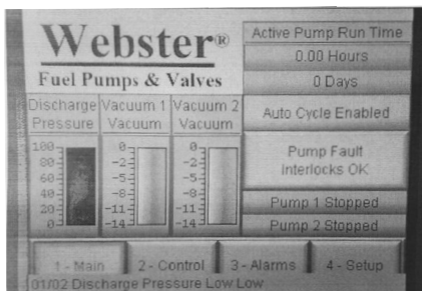

Note: Installer should be familiar with PLC base controls and remote wireless interface in order to enable all the features this panel can provide.

The Complete PLC Duplex Pump and Motor Assembly will also include...

- Flow rates available from 80 GPH up to 1700 GPH
- Discharge pressures from 10-55 psig
- 1725 rpm Direct Drive Motors
- Two Pump and Motor assemblies
- One Compound Gauge on discharge block
- One Discharge connection
- One Regulating/Relief/Back Pressure Valve combination on a common discharge manifold
- Two Inlet Strainers
- Containment Basin (36" x 24") with drain plug, leak sensor and fork lift access
- Inlet Isolation Valves

SPMB and SPMV Pump Selection Table

Selection Table		SPMB and SPMV Series Supply Pumps					
Models and Design Data Table							
Pump Head	Type	Required Motor HP	Required Motor HP	Max Head	Valve Adjustment Range	Max Flow	
Model No.		@ 25 psi	@100 psi			@100 psi	
18BR	Single Stage	.25	.25	200'	No Adjustment	80	
37BR	Single Stage	.25	.25	200'	No Adjustment	160	
47BR	Single Stage	.25	.50	200'	No Adjustment	220	
59BR	Single Stage	.25	.50	200'	No Adjustment	290	
086K	Single Stage	.50	.75	200'	No Adjustment	439	
194K	Single Stage	1	1.75	200'	No Adjustment	900	
237K	Single Stage	1	2	200'	No Adjustment	1115	
388K	Single Stage	2	3.5	200'	No Adjustment	1730	

External Relief or Regulating Valve Required. The RV3003 is mounted to the discharge manifold on the DA package

Supply Pump and Motor Code Breakdown

Examples: SPM-50AT2R213...SPMB-50AT59BR...SPMV-100BT086K-DA...SPMV-50BT086K-DA-PLC

Basic Prefix	Pump Head	Dash	Motor HP	Motor Phase	Motor Enclosure	Webster	Dash	No Letter or
Supply Pump & Motor	Series No Letter-Standard		.25=1/4 hp 500=5hp	Voltage A= 1 Phase B= 3 Phase X=Special 50 or 60cy.	TEFC, OPDP E=Explosion Proof	Pump Head P/N Prefix		Blank = Single DA = Duplex Automatic DM=Duplex Manual DA-PLC PLC Control Panel
SPM	B-V-No Letter		.25-500	A, B or X	T, O or E	Pump #		Blank, DA, DA-PLC or DM

Discharge Manifold Description and Set-up

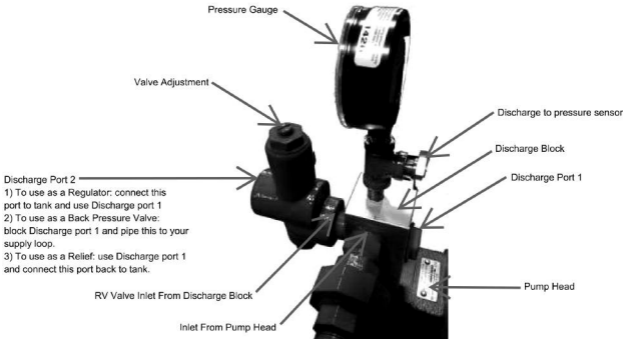

- 1) To use as a Regulator: connect this port to tank and use Discharge port 1
- 2) To use as a Back Pressure Valve: block Discharge port 1 and pipe this to your supply loop.
- 3) To use as a Relief: use Discharge port 1 and connect this port back to tank.

RV-3000

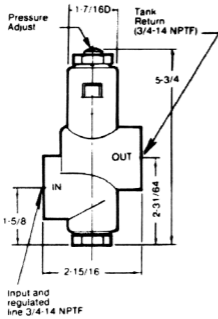

The RV3003 has a 10-55 PSI Adjustment

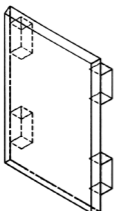
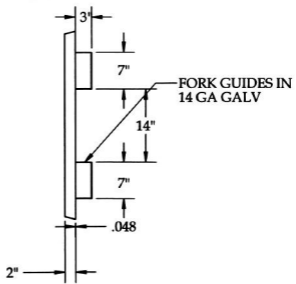
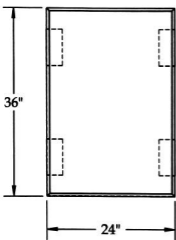
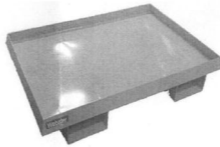
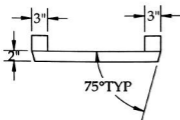

- Note:**
1. Weld Corners Water Tight
 2. All edges hemmed at .5"
 3. No burrs or weld splatter
 4. Minimize burn marks

36" X 24" Containment Basin

P/N 56444-1

SPMB SERIES

Single and Duplex Supply Units



B series transfer pumps are designed to provide efficient pumping of #1 to #6 fuel oils, in capacities from 80 to 290 gallons per hour, at pressures up to 500 PSI (except #1 oil). With high-density gray iron body construction, heat-treated alloy steel gears and shafts, and special antifriction bearings, B series transfer pumps offer superior durability and high mechanical efficiency. Double lip Viton seals are standard. These pumps are also available in pump and motor packages. Available in 115/230 volt single phase or 230/460 volt three phase, simplex, duplex automatic and duplex manual configurations. All B series pumps are UL approved.

Specifications

Gear Sizes:	18B (.35" gear width) 37B (.70" gear width) 47B (1.00" gear width) 59B (1.40" gear width)
Capacity:	80 to 290 GPH @ 1750 RPM #1 to #6 fuel oil @ 75 degrees F., 100 PSI)
Pressures:	#4 to #6 fuel oils - up to 500 PSI #2 fuel oil - up to 350 PSI
Operating Speeds:	To 1725 RPM
Porting: *	$\frac{1}{2}$ " NPTF: Side inlet and side outlet $\frac{3}{4}$ " NPTF: Side inlet and side outlet 59B only
Shaft Seal:	Standard - Double lip type, Viton
Filter:	No internal filter External filter recommended
Relief Valve:	No Relief Valve Use External Relief Valve
Inlet Pressure:	3 PSI MAX
Inlet Vacuum:	10" Hg maximum

UL Listed

SPMB Duplex PUMP/MOTOR UNITS

Available in flow rates from 80 GPH through 290 GPH. Systems can be designed for single phase 115/208/ 230V, 60 or 50CY, or three phase 208/230/460V, 60 or 50CY, applications, The SPM duplex models consist of two pump and motor assemblies with a pre-piped common discharge manifold. One pump operates continuously, with the second providing backup service if the main pump fails. Either automatic (SPM-DA models) or manual (SPM-DM models) controls are available. The duplex automatic series are designed specifically for buildings where a constant supply of oil must be assured...hospitals, apartment buildings, schools and other commercial or industrial buildings. The duplex pump set has a second pump for standby or auxiliary service. Furnished with automatic or manual standby controls, the duplex automatic is equipped with a pressure sensing device which detects loss of pressure of primary pump. If standby pump is brought into service, and alarm sounds which indicates malfunction in primary pump. The electric control circuit on the duplex automatic pump set is equipped with a lead-lag switch to permit manual alternation of pump to provide even pump wear. The manually operated duplex pump sets offer the same protection as the automatic except the standby pump must be turned on manually which requires that maintenance personnel always be available. Available with either SPM or SPMV pump/motor units.

SPMB Ordering Code

SPMB**50****A****T****18BR****DM****1****2****3****4****5**

MOTOR HORSEPOWER (1725 RPM STANDARD)

1	<i>No.</i>	<i>Description</i>
	* 25	.25 HP
	33	.33 HP
	50	.50 HP
	75	.75 HP
	100	1.0 HP
	150	1.5 HP
	200	2.0 HP
	300	3.0 HP

* = only available in 115V or 230V single phase

MOTOR PHASE

2	<i>Code</i>	<i>Description</i>
	A	Single Phase / 60 cycle / 115/208/230 VAC
	B	Three Phase / 60 cycle / 208 / 230 / 460 VAC
	X	Consult factory for other types

MOTOR ENCLOSURE

3	<i>Code</i>	<i>Description</i>
	T	TEFC Std/ thru 2 HP
	O	OPDP Std. over 2 HP
	E	Explosion Proof

When sizing SPMB units, remember that the pressures indicated are at the pump outlet.

All pumps relying on atmospheric pressure to push the fuel oil into them are subject to cavitation. As fuel viscosity (thickness) increases, the tendency for cavitation becomes greater. Therefore, it is best to mount the pump at the base of the tank and to use the largest diameter, shortest length, and straightest inlet possible.

MOTOR HORSEPOWER (1725 RPM STANDARD)

4	<i>Maximum gph Nominal</i>	<i>Under pressure, read horsepower required at 1750 RPM</i>			
		<i>25 psi</i>	<i>100 psi</i>	<i>200 psi</i>	<i>300 psil</i>
<i>18BR</i>	<i>82</i>	<i>.25</i>	<i>.25</i>	<i>.25</i>	<i>.33</i>
<i>37BR</i>	<i>159</i>	<i>.25</i>	<i>.25</i>	<i>.50</i>	<i>.75</i>
<i>47BR</i>	<i>220</i>	<i>.25</i>	<i>.50</i>	<i>.75</i>	<i>1.00</i>
<i>59BR</i>	<i>292</i>	<i>.25</i>	<i>.50</i>	<i>.75</i>	<i>1.50</i>

SPMB Duplex Ordering Code

When ordering SPMB Duplex models add suffix:

“DM,” for manual control models, or “DA,” for automatic control models.

Example: SPMB-50AT/18BR-DA

5	<i>Code</i>	<i>Duplex Units</i>
	<i>DM</i>	<i>Duplex with manual controls</i>
	<i>DA</i>	<i>Duplex with automatic controls</i>

A large diameter inlet pipe or hose necked-down at the pump is preferable to a longer length of similar diameter pipe because the fuel tends to adhere to the inside of the pipe.

When initially starting a unit, it is desirable and sometimes necessary to have a vent valve or plug on the pressure side of the pump to facilitate its priming.

SPMB Series Single and Duplex Supply Units

DIMENSIONS

<i>Motor</i>					
<i>NEMA</i>					
<i>HP</i>	<i>Frame Size</i>	<i>Type (Standard)</i>	<i>A</i>	<i>B</i>	<i>C</i>
.50	56C	TEFC	9.00	8.25	9.20
.75	56C	TEFC	9.00	8.25	9.20
1.00	56C	TEFC	9.00	8.25	10.20
1.50	56C	TEFC	9.00	8.25	11.20
2.00	56C	TEFC	9.00	8.25	11.20
3.00	182TC	OPDP	9.63	11.05	11.00
5.00	184TC	OPDP	9.63	11.05	12.40
7.50	213TC	OPDP	11.63	13.00	13.90

<i>Pump</i>		
<i>Model</i>	<i>E</i>	<i>D</i>
18BR	3.36	(.50HP) 17.06
37BR	3.71	(.75HP) 17.41
47BR	4.05	(.75HP) 17.75
59BR	4.40	(.75HP) 18.10

**SPMB
SINGLE SUPPLY UNIT**

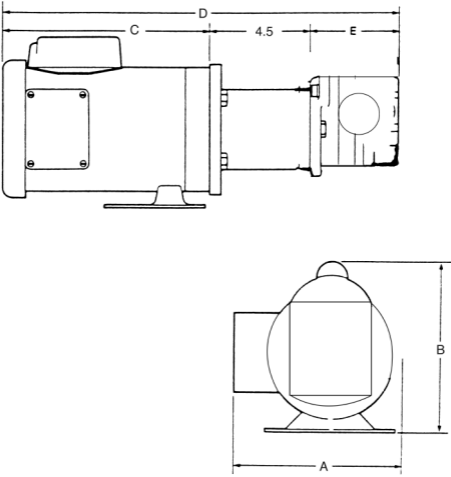

**SPMB
DUPLEX AUTOMATIC SUPPLY UNIT**

(Dimensions are for 3 Phase Duplex Automatic Consult Factory for Single Phase Dimensions)

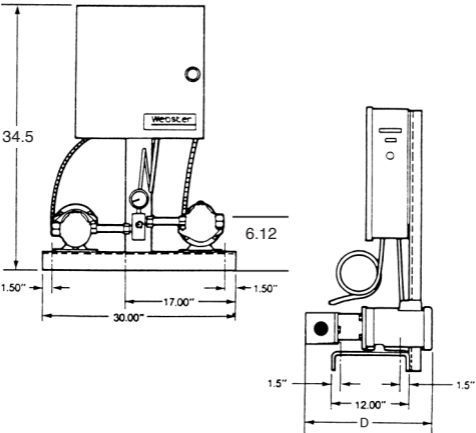

TRANSFER PUMP UNITS

Transfer pumps/motors consist of an electric motor and Webster fuel unit. Each Webster fuel unit has been designed for a variety of needs from fuel supply to fuel transfer. With capacities ranging from 9 to 150 gph at 100 psi, Webster transfer units are capable of satisfying virtually every system supply or transfer need.

SPECIFICATIONS

35223 Series, 35202 Series, 49116 Series

Capacities:

35223 Series—80 to 155 gph at 100 psi.

35202 Series—9 to 65 gph at 100 psi.

49116 Series—31 to 66 gph at 100 psi.

Maximum Working Pressure:

35223 Series—80 to 200 psi.

35202 Series—100 to 300 psi.

49116 Series—100 psi

Motors:

All motors 60 cycle, 1750 rpm, continuous duty 115 volt. 1/6 and 1/4 hp are split phase.

1/2hp is capacitor start—induction run, TEFC with dual 115/230 volt windings.

Fuel Units (Close Coupled to Motor):

35223 Series uses Websters' B Series Fuel Oil Transfer Units.

35202 Series uses Websters' V Series or R Series Fuel Units.

49116 Series uses Websters' 1R00 Series Fuel Transfer Units.

Mounting:

Four bolt foot mount.

Maximum Inlet Vacuum:

10" Hg vacuum.

Use of external filter recommended.

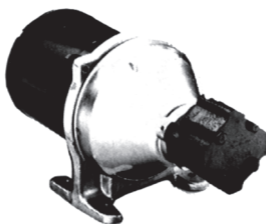

35223 SERIES TRANSFER UNITS

The 35223 Series Pump/Motor Unit consists of a Webster B Series fuel oil transfer pump close coupled to a 1/4 hp electric motor. This unit is designed for transfer of fuel oils #6 or lighter at maximum working pressures up to 200 PSI depending on motor hp.

SELECTION TABLE

35223 Series Pump/Motor Units

Models	Motor Voltage	Motor ho	Pump Model	Maximum Working Pressure	Maximum Outlet Flow at 100psi	Dim. A (max.)	Dim. B
35223-1	115	1/4	18B	200 psi	80 gph	16.04	6.32
35223-3	115	1/4	37B	100 psi	155 gph	16.39	6.67

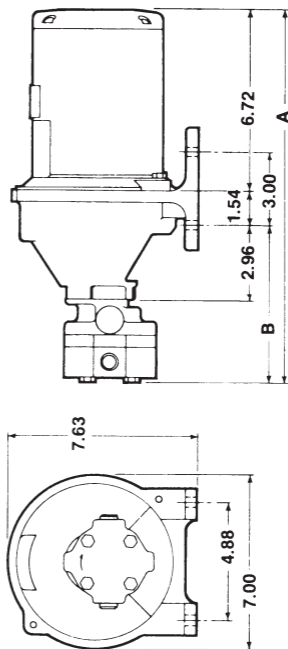

35202 SERIES TRANSFER UNITS

35202 Series Pump/Motor Units consist of a Webster R Series or V Series fuel unit with integral pressure valve, close coupled to a motor. This series is available with 1/6, 1/4 or 1/2 hp electric motors with a pumping capacity to 65 gph at 100 psi.

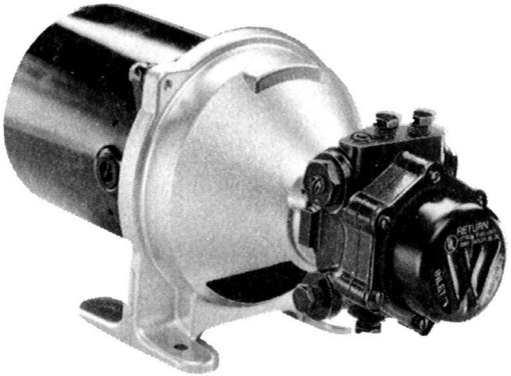

SELECTION TABLE

Models	Motor Voltage	Motor Type No.	Motor hp	Fuel unit Type No.	Maximum Working Pressure psi	Pump Blocked Nozzle Watts	gph at 100 psi	gph at Maximum Working Pressure	Suction Capacity gph
35202	115	34499-3	1/4	2R223C-5BQ14	300	210	30	23	70
35202-2	115	34499-1	1/6	2R111C-5BQ3	150	75	12	10	35
35202-9	Less motor, includes accessories			2R213C-5BQ14	150	130	30	29	70
35202-10	Less motor, includes accessories			2R616C-5BQ14	150	245	65	60	125
35202-27	115	34499-1	1/6	1R162C-4BQ6	125	70	9	7	30
35202-29	115/230 dual	34499-6	1/2	2R626C-5BQ14	300	410	65	50	125
35202-35	115/230 dual	34499-6	1/2	V022C-4D020	300	270	40	20	50
35202-38	115	34499-8	1/3	V002C-4EJ	100	175	65	65	65

Above Capacity in gph at 1725 rpm pumping #2 fuel oil at 75°F.

NOTE: 35202-38 ratings are for 1000 SSU fuel.

Dimensions

Model	A	B	Outlet Port
35202	15.61	7.39	1/4-18 NPTF
35202-9**			1/4-18 NPTF
35202-2	14.09	6.89	1/8-27 NPTF
35202-27	13.47	7.39	1/8-27 NPTF
*35202-29	19.45	5.75	1/4-18 NPTF
35202-10**			
*35202-35	18.83	5.13	1/4-18 NPTF

**Dimensions same as 35202-29 Less Motor

*See Drawing

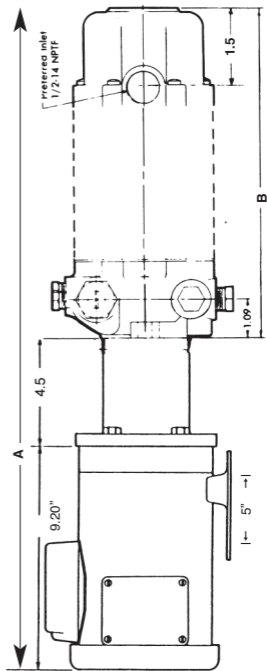
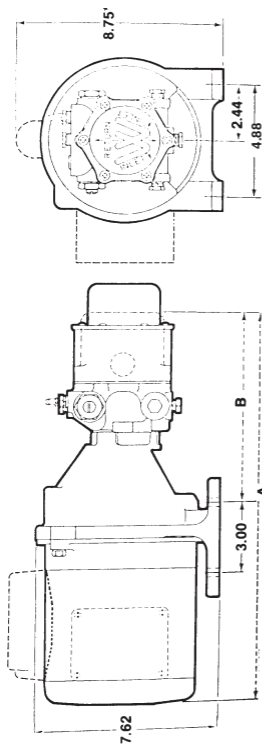

**SPM WITH A "V"
OR "R" SERIES
PUMP HEAD
SINGLE SUPPLY
UNIT USING A 56C
FRAME MOTOR**

*35202-29 AND 35202-35

49116 SERIES TRANSFER UNITS

49116 Series Pump/Motor Units consist of a Webster 1 R00 Series Fuel Transfer Unit close coupled to a 1/4 hp electric motor. This unit requires the use of an external pressure regulating valve. The 49116 Series is capable of up to 66 gph at 100 psi.

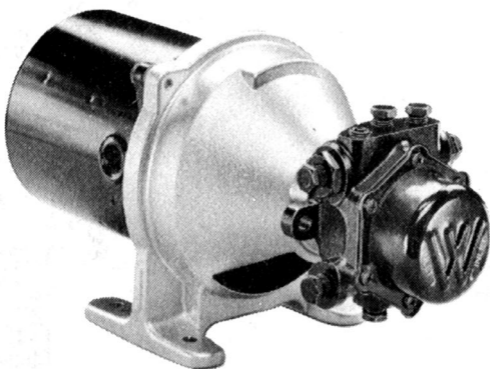

SELECTION TABLE

Models	Replaces Discount Model	Pump Type No.	Suction Capacity gph	Delivery gph 100 psi
49116	35223-19 35223-21	1R003C-4EH	48	31
49116-1	35223-23 35223-25	1R004C-4EH	66	43
49116-2	—	1R006C-4EH	95	66

Capacity in gph at 1725 rpm pumping #2 fuel oil at 75°F

For typical installation suggestions, please refer to the SPM Supply Pump/Motor section.

NOTE: The installation drawings contained in this service guide are intended for reference use only. Consult your local heating contractor for specific installation recommendations and designs which comply with the state and local codes in your area.

Dimensions

Model	A	B
49116	14.44	4.72
49116-1	15.06	5.34
49116-2	15.06	5.34

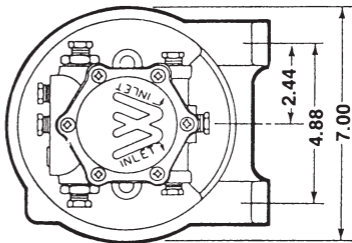
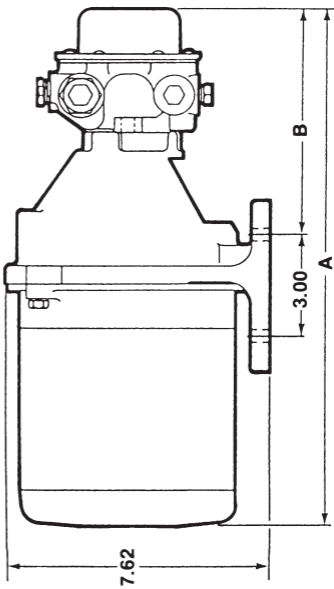

FUEL UNIT ACCESSORIES

MOUNTING ACCESSORIES

Webster oil heat products are recommended for their convenience and ease of installation. Seven types of mounting flanges, brackets, shaft sleeves and couplings are manufactured and stocked for use with Webster fuel units and pumps.

Complete dimension drawings are shown.

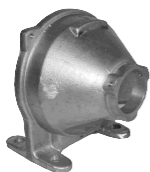

34330



41489



1100013



A43Q7



A45Q1



80316-1

SELECTION TABLE

		Dimensions
Description	Number	
Hi-Foot Flange	A45Q 1	Figure One
4 Bolt Adapter Flange (Nema 56C Motor Mount)	41489	For Standard HUB Figure Three
Horizontal Mounting Flange	A43Q7	Figure Four
Bell Housing	34330	Figure Five
Adapter For B Pump	1100013	Has MTG EARS Figure Two
4 Bolt 56C Adapter Flange for Special 2 Bolt Pump MTG	80316-1	Figure Six

OIL SAFETY VALVES

U/L® LISTED

OIL SAFETY VALVES INSTALLATION INSTRUCTIONS

Webster OSV® valves can be used for the following applications which require slightly different installations:

1. Preventing tank siphoning and oil leaks in the event of line breaks. (See Section “A”)
2. For use with a supply pump (booster pump) to prevent excessive pressure at the inlet of the burner fuel unit. (See Section “B”)

Many state and local codes require a device that will automatically shut off the oil supply before it enters a building should the line between the device and the burner be broken. NFPA standards require that the pressure at the burner fuel

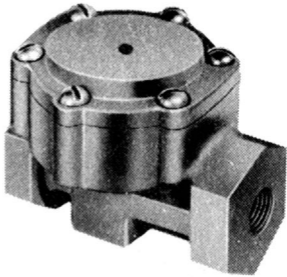

pumps must not exceed 3 PSI. The Webster OSV® satisfies both requirements when properly installed. Check local codes for any special requirements.

SECTION “A”

Using the OSV® valve to help prevent oil spills from broken or corroded lines and fittings.

Operation

A recent Environmental Protection Agency sponsored study found that most oil leaks are found in the piping rather than the tank. Webster OSV® valves help prevent oil spills by stopping oil flow in the event of line breaks caused by corroded lines or leaky fittings. The OSV® 9 is mounted in the supply line as close as possible to the tank. Operation is simple. The OSV® requires a vacuum on its outlet side to open the valve and allow oil flow. When the burner is shut down, there is no vacuum from the fuel unit and the OSV® valve is closed—oil flow is stopped. When the burner starts up, vacuum from the fuel unit opens the OSV®, allowing oil to flow.

If a corroded broken line or a loose fitting causes a leak to develop between the OSV® and burner, air enters the line. Fuel unit vacuum is reduced and the OSV® will not open, preventing tank siphoning and a major spill.

BIO OIL SAFETY VALVE UPGRADE OSV38 and OSV50

Webster currently has an Oil Safety Valve for Bio and Waste Oil applications. This valve is U/L listed for Bio Fuel and is compatible with a wide range of other fuels such as B20-B100, #1-#2 Fuel Oil, Diesel, Kerosene and Waste Oil, with a Temperature Range of -40 to 140°F.

INSTALLATION

The OSV[®] should be mounted on the supply line as close to the tank as possible.

CAUTION: DO NOT mount the OSV[®] more than three feet above the fuel unit inlet or more than three feet above the lowest point in the fuel line connecting the OSV[®] to the burner fuel unit.

See Figures 1 & 2 below.

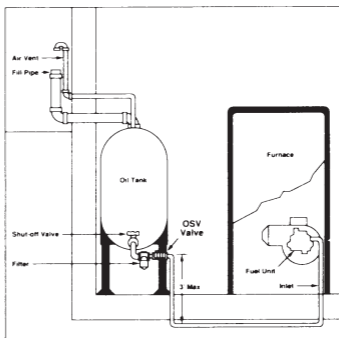

Figure 1. Gravity Feed In Basement

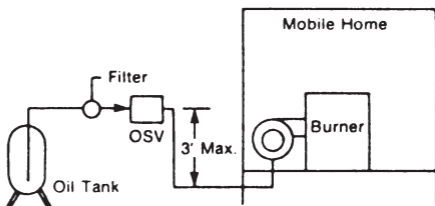

Figure 2. Mobile Home Gravity System

Failure to observe the above caution will compromise valve action and may result in tank siphoning action in the event of a line failure between tank and burner.

TROUBLESHOOTING

The OSV[®] valve will not open during fuel unit operation if there is any air leak in the system between OSV[®] and burner that prevents development of the operational vacuum required. (See Table 1).

If there is no oil flow to burner or prime is lost

- A. Check to see if OSV[®] valve is stopping oil flow. Turn on burner and manually depress OSV[®] diaphragm plate with paper clip to see if burner fires up.

1. Check system vacuum.

Use a vacuum gauge at fuel unit inlet side. Run burner and shutoff. Vacuum should be maintained. Loss of vacuum indicates air leak.

2. Check all above ground fittings and line for air leaks.

3. Conduct a pressure check of the line.

4. If line does not maintain pressure, the line probably has a break and needs replacing.

B. If there is no oil flow even when OSV[®] valve is manually opened then check filter, shut-off or foot valve or tank.

CAUTION: Always disconnect the OSV[®] when blowing out the lines with compressed air or damage to the valve will result.

NOTE: Outside installation may not be suitable where the OSV[®] would be exposed to temperatures below freezing.

Dimensions & Specifications

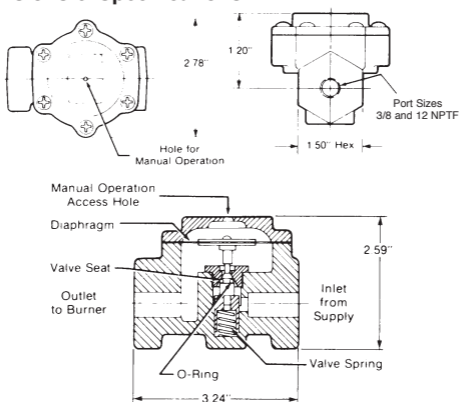

Standard Model use prefix "OSVA"

BIO Model use prefix "OSV"

The BIO OSV valve is U/L listed for Bio Fuel and is compatible with a wide range of other fuels such as B20-B100, #1-#2 Fuel Oil, Diesel, Kerosene, Diesel and Waste Oil.

Temperature Range -40 to 140 Degrees F

SECTION "B"

For use with a supply pump (booster pump) to prevent excessive pressure at the inlet of the burner fuel unit

Operation/Installation

Webster Oil Safety Valves provide important protection in oil burner supply systems with pressurized supply lines. By isolating burner fuel units from supply line pressure sources (a supply pump or overhead tank, for example), the OSV[®] relieves pressure strain on fuel unit inlets and seals.

For this application, the OSV[®] is installed close to the burner assembly. A sustained vacuum at the outlet side of the OSV[®], generated by fuel unit operation, causes the valve to open.

The OSV[®] operates as a pressure reducer, with supply line pressure on the valve inlet side and fuel pump vacuum on the valve outlet side.

In systems with burners connected for one-pipe operation, GPH flow through the valve is the same as the burner nozzle firing rate. In two pipe operation, GPH flow through the valve is the same as the fuel unit suction capacity. Refer to fuel unit manufacturer's specification for inlet suction capacity. Operation of OSV[®] valves in parallel is not recommended.

Recommended Maximum Flow Rates and Pressure

Tbl.1 OSV[®] 38 and OSV[®] 50

Flow thru Valve	Inlet Pressure					
	PSI 5	PSI 15	PSI 30	PSI 40	PSI 50	PSI 60
1 gph	2.5	2.7	3.5	4.5	5.0	5.5
15 gph	2.7	3.0	4.0	5.0	5.5	6.0
32 gph	3.7	4.0	4.7	5.2	6.0	7.0
45 gph	4.0	4.5	5.0	6.0	7.0	
55 gph	4.5	5.0	5.7			
60 gph	5.0	5.2	6.0	Do not operate		
70 gph	5.5	6.0	in this region			

Vacuum (inches Hg) to operate valve is shown for various flow and pressure conditions.

Values given are averages of test results and may vary slightly.

Entrapment Caution

In supply systems having a check valve on the supply pump discharge, an entrapment condition may exist between the supply pump and OSV[®]. In the burner OFF condition, cold oil in the line expands when heating to room temperature, causing a line pressure increase that may prevent the OSV[®] from operating, or may cause leakage at the threaded joints. The condition may be observed by use of a pressure gauge at the inlet side of the OSV[®], or on the discharge side of the supply pump check valve. Correction requires use of a pressure relief valve as shown in Figure 3, set to insure a maximum 60 PSI at any OSV[®] inlet under all conditions.

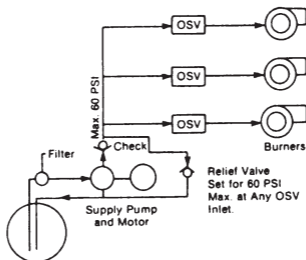

Figure 3. Supply Pump Systems — Multi Level

OPEN LOOP SYSTEM

To insure a flooded supply line, a standpipe before the junction of the supply line with the return line is required. The standpipe on the supply line must be at least three feet higher than any point in the supply line system before joining the return line. Use of a Webster 48598 vacuum breaker is recommended.

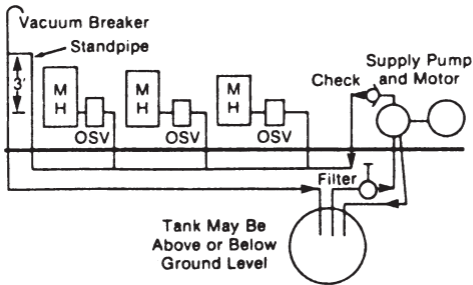

Figure 4. Central Supply Systems for Mobile Homes
GENERAL CONSIDERATIONS

PORTING CONNECTIONS

The OSV[®] valve is installed in the supply line between the tank and burner. Its location depends on the application (see sections A & B). The OSV[®] "IN" port is connected to the tank side. The OSV[®] "OUT" port is connected to the burner side of the line. Non hardening pipe dope is recommended for use on the fitting threads. Do not use teflon tape, as it may void all warranties.

MOUNTING

The OSV[®] can be mounted in any position. In those environments where dirt or moisture is particularly a problem, the preferred position is with the cover down. This allows any moisture from the diaphragm area to drain out the manual access hole.

FILTER

A dependable in-line filter is recommended between the tank and OSV[®] to help assure optimum valve performance. Dirt on the valve seat area could prevent the valve from sealing tightly.

PRIMING

For priming purposes, the OSV[®] can be manually operated by inserting a paper clip or stiff wire through the manual access hole, and depressing the diaphragm plate. Remove the wire immediately if oil appears at the fuel unit vent, the burner fires up, or there is any sign of oil at the burner fuel unit.

CHECK LOCAL CODES

The installer is responsible for complying with all applicable codes. Typical installation diagrams are shown for reference only.

REGULATING VALVES FOR OIL HEATING SYSTEMS

RV SERIES

Webster RV Series valves are designed to provide fuel oil pressure regulation in oil heating applications such as transfer or supply pump systems or high firing capacity burners. RV valves will handle #1 through #6 grade fuel oil in rated pressures ranging from 0 to 500 psi (0 to 34.5 bar). RV-2100 Series models regulate pressure for capacities to 150 gph (568 l/hr) and RV-3000 series valves regulate pressure to 600 gph (2270 l/hr). RV-2000 models regulate pressure and also provide delivery cut-off for capacities to 100 gph (378 l/hr).



SPECIFICATIONS

RV-2000

For all fuel oils, #1 through #6. Combines pressure regulation and cut-off. Chrome plated piston valve and improved composition sealing disc resist corrosion; gives positive seal and sharp, clean cut-off Capacities to 100 gph.

RV-2100

Same as RV-2000 except does not have delivery cut-off. Pressure regulating only. Capacities to 150 gph.

RV-3000

Same as RV-2100 except capacities to 600 gph.

Dimensions

RV-3000

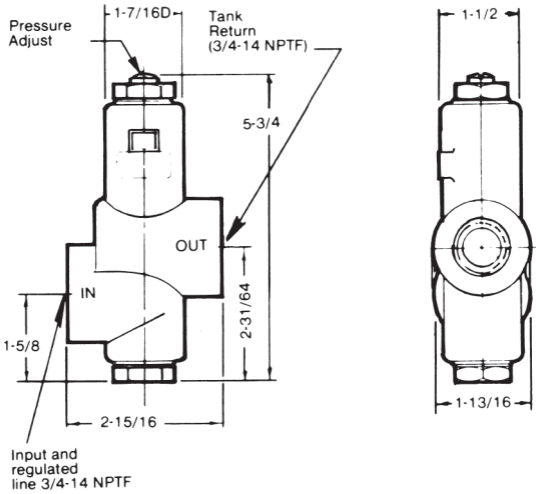

RV-2000

RV-2100

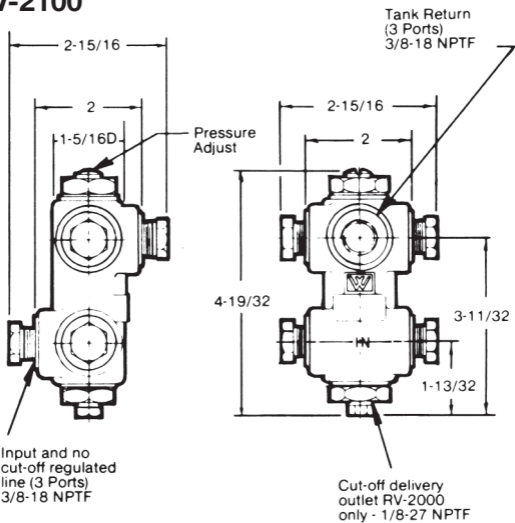

SELECTION TABLE					
Model			Adjustment	Capacity	Factory
Number	Porting	Description	Range	GPH	Set PSI
RV2001	3/8	Regulating with Cut-Off	100-165	100	100†
RV2002	3/8	Regulating with Cut-Off	100-330	100	100†
RV2003	3/8	Regulating with Cut-Off	10-25	100	10†
RV2004	3/8	Regulating with Cut-Off	40-110	100	100†
RV2101	3/8	Regulating	100-165	150	100†
RV2102	3/8	Regulating	100-330	150	100†
RV2102E	3/8	Regulating	100-330	150	250†
RV2103	3/8	Regulating	10-25	150	10†
RV2104	3/8	Regulating	40-140	150	100†
RV2101-1	1/4	Special	100-165	150	100†
RV2101-4	1/4	Regulating	100-165	150	150*
RV2102-4	1/4	Valves	100-330	150	150†
RV2102-4A	1/4	(See Note 1)	100-330	150	100*
RV2102-4B	1/4	"	100-330	150	125*
RV2102-4C	1/4	"	100-330	150	150*
RV2102-4D	1/4	"	100-330	150	200*
RV2102-4E	1/4	"	100-330	150	250*
RV2102-4J	1/4	"	100-330	150	300*
RV2104-2	1/4	"	80-140	150	100*
RV2104-3	3/8	"	80-140	150	100*
RV2104-4	1/4	"	80-140	150	100*
RV3000	3/4	Regulating	250-550	600	250†
RV3001	3/4	Regulating	50-330	600	100†
RV3001DAR	3/4	Special Regulating	50-330	600	100†
RV3002	3/4	Regulating	50-220	600	100†
RV3003	3/4	Regulating	10-55	600	10†

(PSI Range and setting based on 50 GPH flow, #2 Fuel Oil, except RV3000 series is based on 150 GPH flow)

Valve may be reset at installation to meet system requirement.

*Valve stamped at factory with present pressure.

†Valve not stamped with factory present pressure.

NOTE 1: These special valves meet the requirements of the New York City's Board of Air Resources. The valve body dimensions are the same as those shown at the right for the RV2000 and RV2100 series valves. Differences are: 1. The top and bottom valve and caps are taper pinned to the body to prevent removal. 2. The pressure adjustment seal screw and washer once installed by the customer, cannot be removed to prevent tempering with the set pressure. 3. All inlets and outlets are tapped for 1/4-18 NPTR fittings except the RV2104-3 which is 3/8-18 NPTF.

INSTALLATION

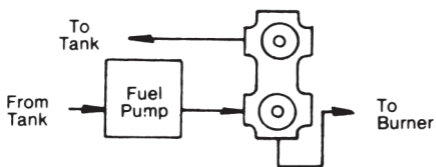

RV-2000

Valve Regulation with Cutoff

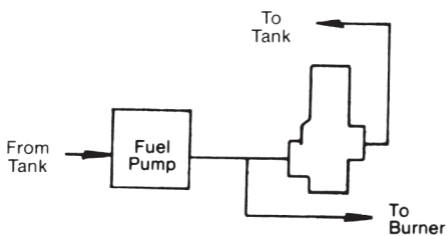

RV-3000

Valve Regulation without Cutoff

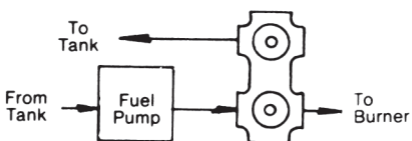

RV-2100

Valve Regulation without Cutoff

Relief Valve Installation

RV-2000

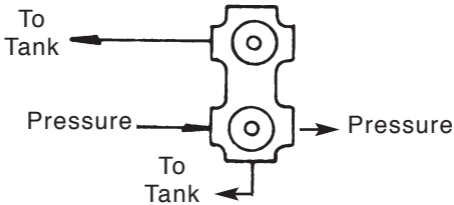
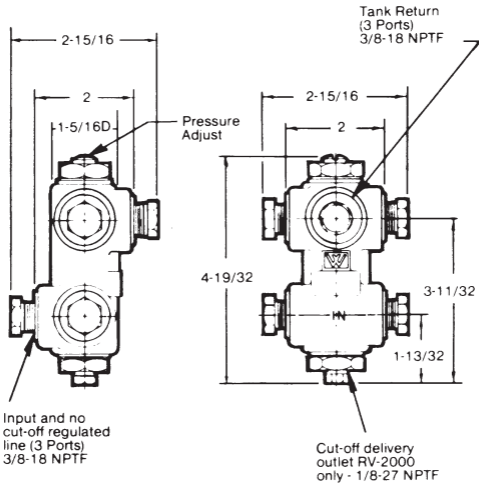

The RV-2000 series regulating valves can also be used as a relief valve. Designed to provide system pressure relief for #1 through #6 fuel grades and for rated pressure ranges from 0 to 500 psi at 150 gph or less.

The following adjustment ranges are available:

10-25 psi use RV-2003

40-110 psi use RV-2004

100-330 psi use RV-2002

VACUUM BREAKER (48598)

Incorporates Viton "O" Ring seat, 3/8-18 NPTF ports.
 Can be used as a suction line check valve.

INSTALLATION DATA

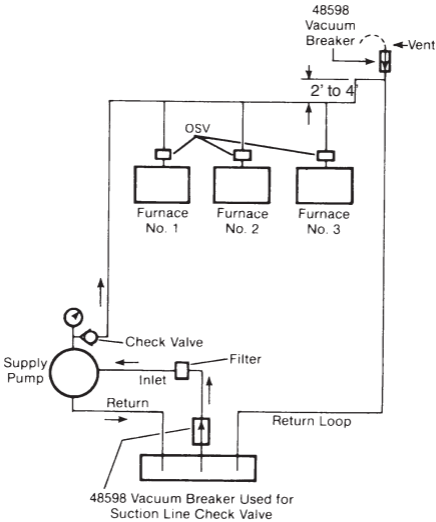
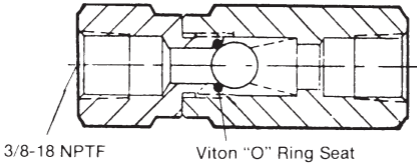

Inches
 Mercury
 Hg

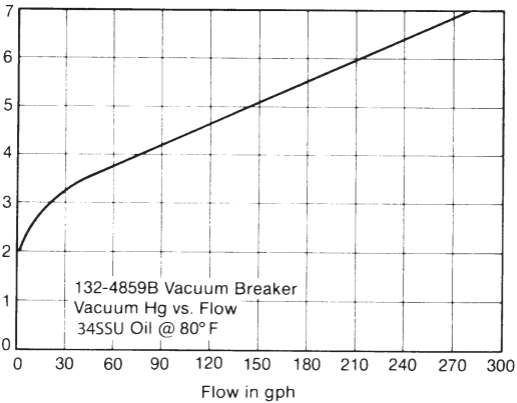

Troubleshooting

GENERAL PUMP PROBLEMS

- Noisy pump
- Pump will not prime
- Rumble coming from burner at start-up
- Oil leaking from pump cover gasket or blown cover gasket
- Pump loses prime after an extended shutdown
- Vacuum coming from return port on oil pump (two pipe installation)
- Pump seizes at start-up, blows seal, damage to discharge pressure gauge
- Supply unit does not run
- Unit runs but no oil reaches supply pump
- Unit supplies oil to distribution system, but no delivery of oil at OSV valves
- Oil delivery at OSV valves, but burners do not fire
- Burner pump seal damaged
- Pressure increases in supply line after shutdown
- Oil Safety Valve does not open

Noisy pump

Check for air leaks

Check for high vacuum condition, (10 in. for single stage and 15 in. for two stage pumps)

Pump will not prime

Measure suction inlet vacuum, should not exceed 15 in. of vacuum

Check that all plugs and suction line connections are airtight

Be certain by-pass plug is in position on two pipe installation

Use adequate size suction line

Be certain suction line filter or strainer has adequate capacity

Rumble coming from burner at start-up

Check cutoff at pump or external solenoid

Oil leaking from pump cover gasket(s) blown cover gasket(s)

Check for correct pump rotation

Pump loses prime after an extended shutdown

Check all pipe connections for air leaks

Return line not submerged in oil

In supply pump applications the return loop may need a vacuum breaker installed to prevent siphoning

Vacuum coming from return port on oil pump
(two pipe installation)

By-pass plug not installed

If by-pass plug is installed check for blocked suction line

Pump seizes at start-up. blows seal. damage
to discharge pressure gauge

Check for blocked return line or drain port from pump

By-pass plug should be removed on single pipe installation

SUPPLY PUMP PROBLEMS

Supply Unit does not run

Check motor electrical connections

Check for obstruction in return line such as a reversed check valve

Check circuit breaker and correct possible overload

Unit runs. but no oil reaches supply pump

Measure suction inlet vacuum, should not exceed 15 in. of vacuum

Check that all plugs and suction line connections are airtight

Be certain by-pass plug is in position

Use adequate size suction line

Be certain suction line filter or strainer has adequate capacity

Unit supplies oil to distribution system, but no delivery
of oil at OSV valves

Confirm specified unit can provide needed vertical discharge pressure

Check that all supply line connections are air and oil tight

Use adequate size supply line

Minimize supply line restrictions

Prime pump and purge supply lines of air

Check pump pressure settings

Oil delivery at OSV valves. but burners do not fire

Confirm specified unit can provide needed capacity (Size to firing rate for single pipe burners or size to gear set capacity for two piped burners)

In pressurized system, adjust pressure to develop a reading of 10-15 PSI at the most remote or highest burner

In open loop system, install standpipe, back pressure valve, vacuum breaker or over-sized drop pipe

Check to assure that pressures at OSV inlet does not exceed maximum of 60 PSI

Check for leaking or damaged OSV

Check for line failure between OSV and burner pump

Check burner for fuel pump failure or ignition problems

Burner pump seal damaged

Install OSV to assure pressure at burner pump does not exceed 3 PSI

Install pressure relief valve if entrapment condition is suspected

Pressure increases in supply line after shutdown

Check to assure that pressures at OSV inlet does not exceed maximum of 60 PSI

Install pressure relief valve if entrapment condition is suspected

OIL SAFETY VALVE PROBLEMS

Oil Safety Valve does not open

Too much pressure at inlet of valve

Flow exceeds recommended flow rate for valve.

Entrapment condition (expansion of oil in supply line)

Check for air leaks between the OSV valve and burner pump

MANUFACTURERS REPS

Webster and its Representatives have the resources and technical background to answer any installation or service questions you may have.

Please refer to the listing below for the Webster Representative near you.

SHANE MILLER

G. MILLER CO.

901 River Lane

Loves Park, IL 61111

Tele: 815-964-5692 Fax: 815-964-5770

Cell: 815-985-3880

shane@gmillercompany.com

www.gmillercompany.com

STATES
IN / IL / MN / WI
KY / ND / SD

MONS KING

ETC SALES, INC.

PO Box 235

Paoli, PA 19301

Tele: 610-296-3527 Fax: 610-640-4271

Cell: 610-659-2763

monsgwen@msn.com

STATES
DE / MD / VA
E.PA / NJ

TOM JOHNS

TRADREP LTD

3801 Wiltshire Road

Chagrin Falls, OH.

Tele: 440-247-3880 Fax: 440-247-3882

tradrep@sbcglobal.net

STATES
OH / WV / W.PA / MI

LENNIE DeANGELO

PILGRIM SALES

18 Pilgrim Road

Marblehead, MA 01945

Cell: 617-548-2813 Fax: 781-639-1157

deangelo@pilgrimsales.net

STATES
ME / NH / MA
CT / VT / RI

GEORGE NIKIFOROV, INC

200 Park Ave., South

Suite 514

New York, NY 10003

Tele: 212-473-4555 Fax: 212-473-5925

international@geonikinc.com

www.geonikinc.com

INTERNATIONAL

DON KNUTH

CC Marketing

61 Pennsylvania Ave.

Apalachin, NY 13732

Tele: 518-882-5201 Fax: 518-795-9157

dknuth@nycap.rr.com

STATES
NY

BILL GLUCKIN

COMFORT ZONE SALES

2870 Milburn Ave.

Baldwin, NY 11510

Tele: 516-442-0388 Fax: 516-442-0389

Cell: 516-945-7439

wgluckin@comfortzonesalesinc.com

LONG ISLAND, NY

CURTIS ZAHALKA
WEBSTER FUEL PUMPS & VALVES

219 Hahn Road
Frankfort, KY 40601
Tele: 502-223-0025 Fax: 502-223-5629
Toll Free: 800-766-1233
czahalka@cctoolinc.com
webster@cctoolinc.com

INSIDE SALES

E.S. GALLAGHER SALES

920 Caledonia Road
Unit 3B
Toronto, Ontario M6B 3Y1
Tele: 416-789-5385 Fax: 416-781-6734
info@esgallagher.com
www.esgallagher.com

CANADA

NOTES