

REGULATING VALVES FOR OIL HEATING SYSTEMS

RV SERIES

Webster RV Series valves are designed to provide fuel oil pressure regulation in oil heating applications such as transfer or supply pump systems or high firing capacity burners. RV valves will handle #1 through #6 grade fuel oil in rated pressures ranging from 20 to 500 psi (1.4 to 34.5 bar). RV-2100 Series models regulate pressure for capacities to 150 gph (568 l/hr) and RV-3000 Series valves regulate pressure to 600 gph (2270 l/hr). RV-2000 models regulate pressure and also provide delivery cutoff for capacities to 100 gph (378 l/hr).



RV-2000
RV-2100



RV-3000

SPECIFICATIONS

RV-2000

For all fuel oils, #1 through #6. Combines pressure regulation and cut-off. Chrome plated piston valve and improved composition sealing disc resist corrosion; gives positive seal and sharp, clean cut-off. Capacities to 100 gph.

RV-2100

Same as RV-2000 except does not have delivery cut-off. Pressure regulating only. Capacities to 150 gph.

RV-3000

Same as RV-2100 except capacities to 600 gph.

Dimensions

RV-3000

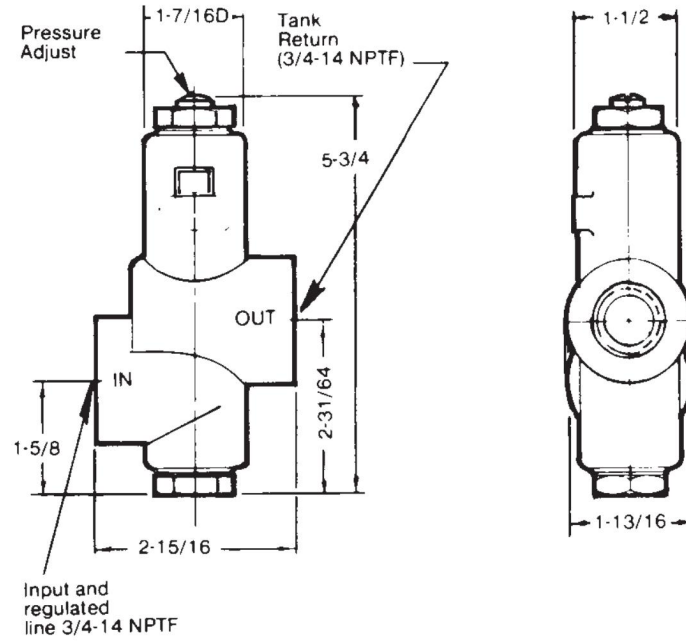

**RV-2000
RV-2100**

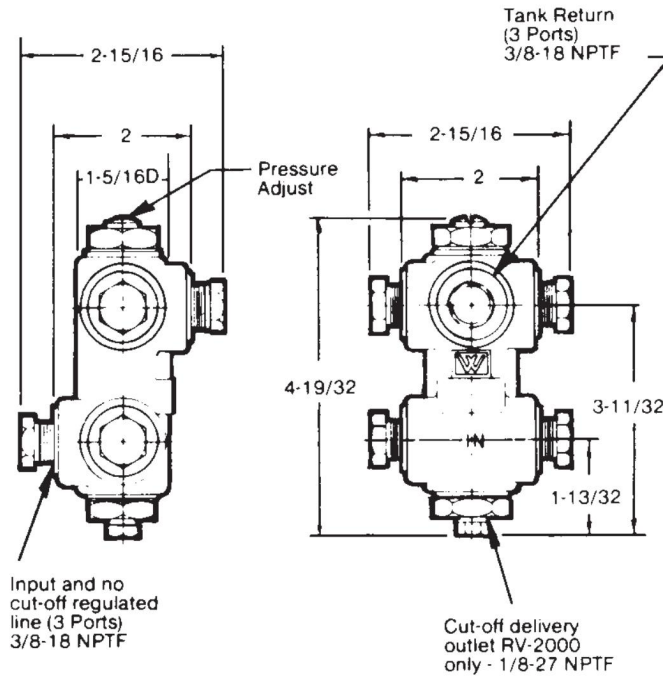

SELECTION TABLE

Type Number	Porting	Description	Adjustment Range (psi)	Preset Capacity gph (Max.)	Factory Set Pressure (psi)
RV-2001			100-165	100	100†
RV-2002		Regulating & Cut-off Valve	100-330	100	100†
RV-2003	3/8		10-25	100	10†
RV-2004			40-110	100	100†
RV-2101			100-165	150	100†
RV-2102		Regulating Valve	100-330	150	100†
RV-2103	3/8		10-25	140	10†
RV-2104			80-140	150	100†
RV-3000			250-550	600	250†
RV-3001		Regulating Valve	50-330	600	100†
RV-3002	3/4		50-220	600	100†
RV-3003			10-55	600	10†
RV-2101-4	1/4	Special Regulating	100-165	150	150*
RV-2102-4	1/4		100-330	150	150†
RV2102-4A	1/4		100-330	150	100†
RV2102-4B	1/4		100-330	150	125†
RV2102-4C	1/4		100-330	150	150†
RV2102-4J	1/4		100-330	150	300†
RV-2104-3	3/8	Valves (See Note 1)	80-140	150	100*
RV-2104-4	1/4		80-140	150	100*

(PSI Range and Setting based on 50 gph flow, #2 Fuel Oil, except RV-3000 Series is based on 150 gph flow.)

Valve may be reset at installation to meet system requirement.

*Valve stamped at factory with preset pressure.

†Valve not stamped with factory preset pressure

NOTE 1: These special valves meet the requirements of the New York City's Board of Air Resources. The valve body dimensions are the same as those shown at the right for the RV-2000 and RV-2100 Series valves. Differences are: 1) The top and bottom valve end caps are taper pinned to the body to prevent removal. 2) The pressure adjustment seal screw and washer, once installed by the customer, cannot be removed to prevent tampering with the set pressure.

INSTALLATION DATA

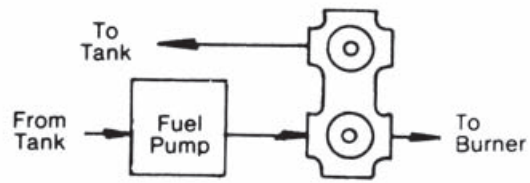
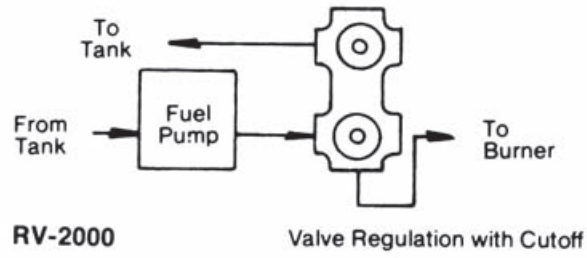

RV-2100 Valve Regulation without Cutoff

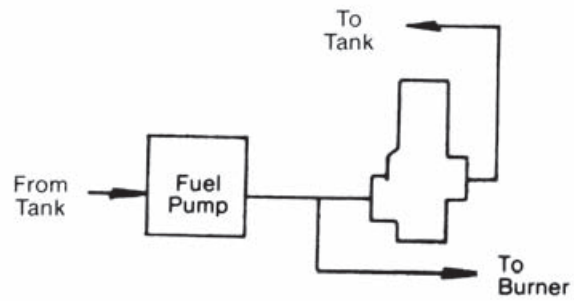

RV-3000 Valve Regulation without Cutoff