

FUEL UNIT ACCESSORIES

MOUNTING ACCESSORIES

Webster oil heat products are recommended for their convenience and ease of installation. Seven types of mounting flanges, brackets, shaft sleeves and couplings are manufactured and stocked for use with Webster fuel units and pumps.

Complete dimension drawings are shown.



34330



1100012



41489



A43Q7



A45Q1

SELECTION TABLE

Description	Number	Dimensions
		(Reverse Side)
Hi-Foot Flange	A45Q 1	Figure One
4 Bolt Adapter Flange (Nema 56C Motor Mount)	41489	Figure Three
Horizontal Mounting Flange	A43Q7	Figure Four
Bell Housing	34330	Figure Five
Adapter For B Pump	1100012	Figure Two

Accessory Dimensions

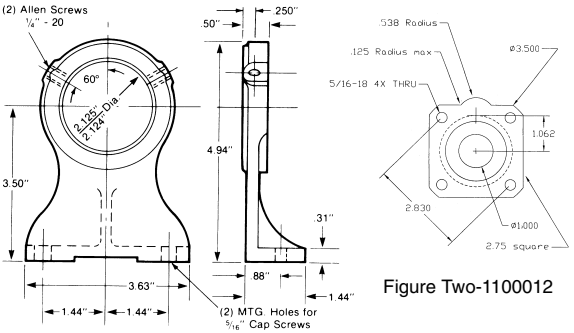

Figure One — A45Q1

Figure Two-1100012

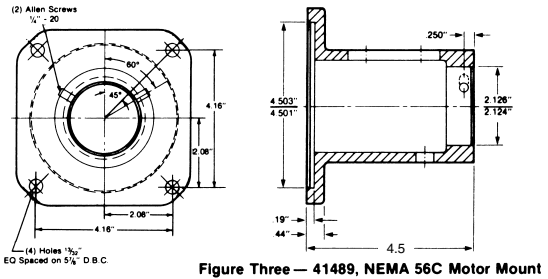

Figure Three — 41489, NEMA 56C Motor Mount

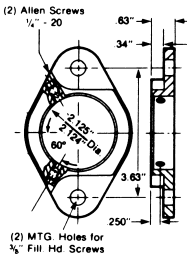
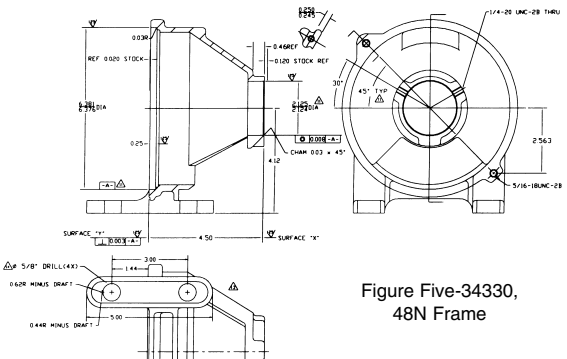

Figure Four — A43Q7



**Figure Five-34330,
48N Frame**